

INSTALLATION MANUAL

**R-410A
XN SERIES**

3 - 5 Ton

60 Hertz



TABLE OF CONTENTS

| | | | |
|--|----|---|----|
| General | 2 | Free Cooling Operation | 31 |
| Installation | 5 | Power Exhaust | 31 |
| Installation Safety Information | 5 | Operation | 32 |
| Limitations | 5 | Checking Supply Air CFM | 42 |
| Location | 6 | Operation | 43 |
| Rigging And Handling | 7 | Sequence Of Operation | 43 |
| Ductwork | 12 | No Outdoor Air Options | 43 |
| Condensate Drain | 12 | Cooling Operation Errors | 44 |
| Compressors | 12 | Heating Sequence Of Operations | 45 |
| Filters | 13 | Defrost Termination | 45 |
| Power And Control Wiring | 13 | Interval between Defrosts | 45 |
| Optional Electric Heat | 30 | Forced Defrost | 45 |
| Options/Accessories | 30 | Safety Controls | 45 |
| Economizer And Power Exhaust Set Point Adjustments | 30 | Start-up (Cooling) | 46 |
| Economizer Sequences | 30 | Simplicity SE Control Board Navigation Components | 47 |
| Dry Bulb Changeover | 31 | Simplicity™ SE (Smart Equipment) Firmware Version 3 | |
| Single Enthalpy Changeover | 31 | Basic Unit Control Board Navigation Examples: | 48 |
| Dual Enthalpy Changeover | 31 | Maintenance | 55 |
| Auto | 31 | Normal Maintenance | 55 |
| | | Start-Up Sheet | 56 |

LIST OF TABLES

| | | | |
|---|----|--|----|
| 1 XN036-060 Unit Limitations | 6 | 11 Altitude/Temperature Correction Factors | 37 |
| 2 Weights and Dimensions | 8 | 12 XN Blower Performance Side Duct | 39 |
| 3 XN036-060 Unit Accessory Weights | 8 | 13 XN Blower Performance Bottom Duct | 40 |
| 4 XN036-060 Unit Clearances | 10 | 14 Belt Drive RPM Selection | 41 |
| 5 XN036-060 Utilities Entry | 11 | 15 Indoor Blower Specifications (Belt Drive) | 41 |
| 6 Control Wire Sizes | 14 | 16 Power Exhaust Specifications | 42 |
| 7 Electrical Data | 16 | 17 Additional Static Resistance | 43 |
| 8 XN036-060 Physical Data | 28 | 18 Electric Heat Limit Setting | 46 |
| 9 Electric Heat Minimum Supply Air | 30 | 19 Electric Heat Anticipator Setpoints | 46 |
| 10 Simplicity SE Economizer Board Details | 32 | 20 Simplicity SE UCB Details | 50 |

LIST OF FIGURES

| | | | |
|--|----|--|----|
| 1 XN036-060 Component Location | 6 | 9 XN036-060 Roof Curb | 11 |
| 2 Unit 4 Point Load Weight | 8 | 10 Condensate Drain | 12 |
| 3 Unit 6 Point Load Weight | 8 | 11 Compressor Restraining Bracket | 13 |
| 4 Center of Gravity | 8 | 12 Typical Field Control Wiring | 15 |
| 5 XN036-060 Heat Pump/Electric Heat Front View Physical Dimensions | 9 | 13 SE-ECO1001-0 Economizer Controller | 32 |
| 6 XN036-060 Fixed Outdoor Air Motorized Damper Rain Hood Physical Dimensions | 10 | 14 Belt Adjustment | 36 |
| 7 XN036-060 Disconnect Location | 10 | 15 Altitude/Temperature Correction Factors | 37 |
| 8 XN036-060 Unit Side Duct Openings | 11 | 16 Pressure Drop Across Coil | 42 |
| | | 17 Unit Control Board | 50 |

General

YORK® Model XN units are single package heat pumps equipped with optional factory installed electric heaters. These units are designed for outdoor installation on a rooftop or slab.

The units are completely assembled on rigid, permanently attached base rails. All piping, refrigerant charge, and electrical wiring is factory installed and tested. The units require electric power, duct connections and fixed outdoor air intake damper (units without economizer or motorized damper option only) at the point of installation.

The supplemental electric heaters have nickel-chrome elements and utilize single point power connection.

Safety Considerations

This is a safety alert symbol. When you see this symbol on labels or in manuals, be alert to the potential for personal injury.

Understand and pay particular attention the signal words **DANGER**, **WARNING** or **CAUTION**.

DANGER indicates an **imminently** hazardous situation, which, if not avoided, **will result in death or serious injury**.

WARNING indicates a **potentially** hazardous situation, which, if not avoided, **could result in death or serious injury**.

CAUTION indicates a potentially hazardous situation, which, if not avoided **may result in minor or moderate injury**. It is also used to alert against unsafe practices and hazards involving only property damage.

WARNING

Improper installation may create a condition where the operation of the product could cause personal injury or property damage. Improper installation, adjustment, alteration, service or maintenance can cause injury or property damage. Refer to this manual for assistance or for additional information, consult a qualified contractor, installer or service agency.

CAUTION

This product must be installed in strict compliance with the installation instructions and any applicable local, state and national codes including, but not limited to building, electrical, and mechanical codes.

WARNING

Before performing service or maintenance operations on unit, turn off main power switch to unit. Electrical shock could cause personal injury. Improper installation, adjustment, alteration, service or maintenance can cause injury or property damage. Refer to this manual. For assistance or additional information consult a qualified installer or service agency.

CAUTION

This system uses R-410A Refrigerant which operates at higher pressures than R-22. No other refrigerant may be used in this system. Gage sets, hoses, refrigerant containers and recovery systems must be designed to handle R-410A. If you are unsure, consult the equipment manufacturer. Failure to use R-410A compatible servicing equipment may result in property damage or injury.

Due to system pressure, moving parts, and electrical components, installation and servicing of air conditioning equipment can be hazardous. Only qualified, trained service personnel should install, repair, or service this equipment. Untrained personnel can perform basic maintenance functions of cleaning coils and filters and replacing filters.

Observe all precautions in the literature, labels, and tags accompanying the equipment whenever working on air conditioning equipment. Be sure to follow all other applicable safety precautions and codes that apply.

Wear safety glasses and work gloves. Use quenching cloth and have a fire extinguisher available during brazing operations.

Inspection

As soon as a unit is received, it should be inspected for possible damage during transit. If damage is evident, the extent of the damage should be noted on the carrier's freight bill. A separate request for inspection by the carrier's agent should be made in writing.

Reference

Additional information is available in the following reference forms:

- Technical Guide - ZE/ZF/ZR/XN/XP036 thru 072, 251933
- General Installation - XN036-060, 1189544

Renewal Parts

Contact your local York® parts distribution center for authorized replacement parts.

Approvals

Design certified by CSA as follows:

1. For use as a heat pump only with or without optional electric heat.
2. For outdoor installation only.
3. For installation on combustible material.

CAUTION

This product must be installed in strict compliance with the enclosed installation instructions and any applicable local, state, and national codes including, but not limited to, building, electrical, and mechanical codes.

WARNING

Improper installation may create a condition where the operation of the product could cause personal injury or property damage.

CAUTION

This system uses R-410A Refrigerant which operates at higher pressures than R-22. No other refrigerant may be used in this system.

Nomenclature

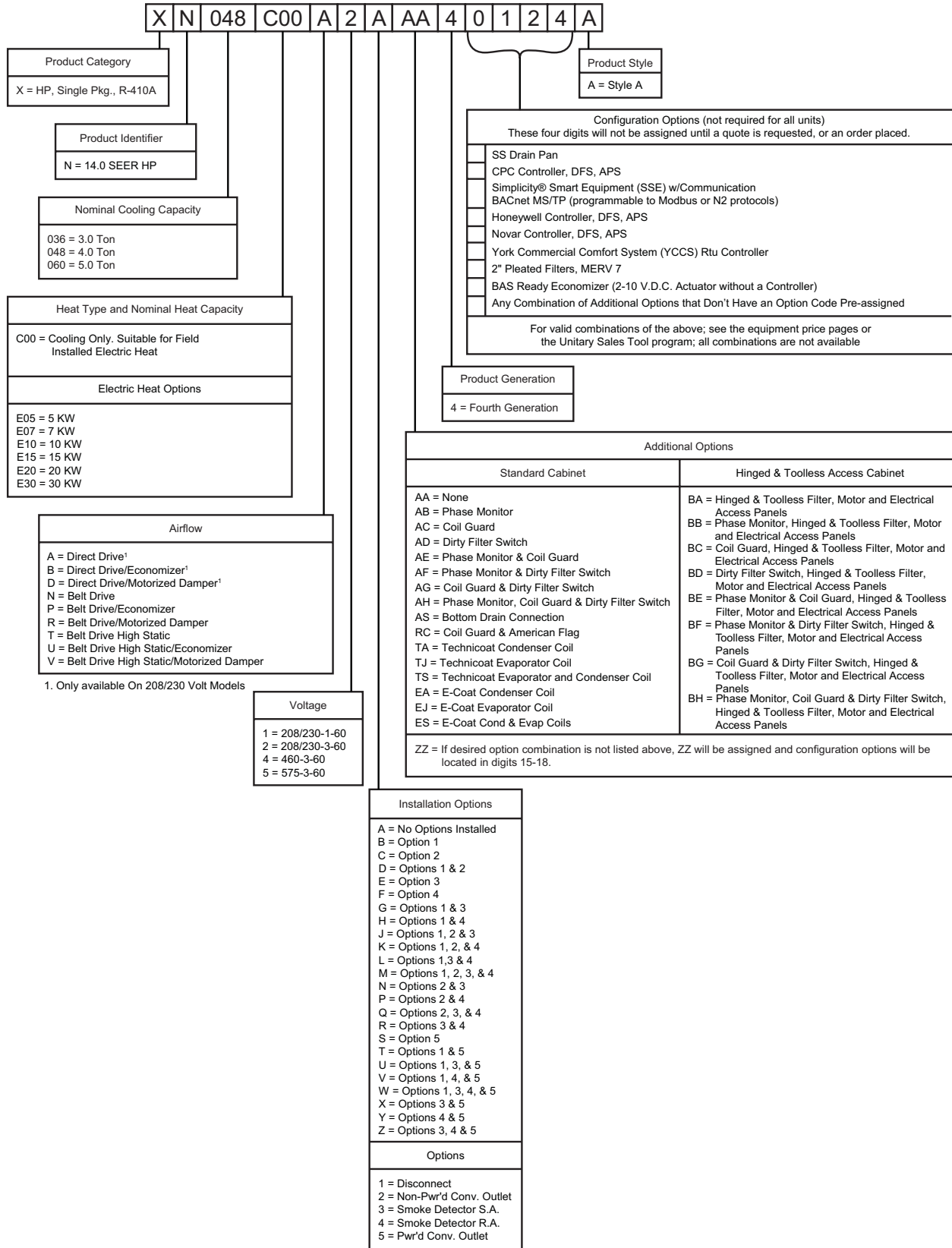

Installation

Installation Safety Information

Read these instructions before continuing this appliance installation. This is an outdoor combination heating and cooling unit. The installer must assure that these instructions are made available to the consumer and with instructions to retain them for future reference.

1. Install this unit only in a location and position as specified on Page 6 of these instructions.
2. This equipment is not to be used for temporary heating of buildings or structures under construction.
3. If a factory option convenience outlet is installed, the weatherproof outlet cover must be field installed. The cover shall be located behind the blower access panel. To install the cover, remove the shipping label covering the convenience outlet and attach the cover to the unit using the (4) screws provided.

CAUTION

208/230-3-60 and 380/415-3-50 units with factory installed Powered Convenience Outlet Option are wired for 230v and 415v power supply respectively. Change tap on transformer for 208-3-60 or 380-3-50 operation. See unit wiring diagram.

Limitations

These units must be installed in accordance with the following:

In U.S.A.:

1. National Electrical Code, ANSI/NFPA No. 70 - Latest Edition
2. Local building codes
3. Local utility requirements

In Canada:

1. Canadian Electrical Code, CSA C22.1
2. Local plumbing and waste water codes

3. Other applicable local codes.

Refer to unit application data found in this document.

If components are to be added to a unit to meet local codes, they are to be installed at the dealer's and/or customer's expense.

Size of unit for proposed installation should be based on heat loss/heat gain calculation made according to the methods of Air Conditioning Contractors of America (ACCA).

This unit is not to be used for temporary heating of buildings or structures under construction.

It is permitted to use the unit for heating and cooling of buildings or structures under construction where the application and use must comply with all manufacturer's installation instructions including:

- Unit must be operated under thermostatic control;
- Return and supply air ducts must be sealed to the unit;
- Air filters in place;
- Return air temperature maintained between 55°F (13°C) and 80°F (27°C);
- Upon completion of the construction phase and prior to formal start up and commissioning, the unit, duct work and components should be thoroughly cleaned and inspected to assure that operation of the unit during construction has not contaminated the unit.

NOTE: Should the unit be used during the construction phase the standard limited warranty provisions go into effect once the unit is placed into operation.

CAUTION

The Simplicity® SE control board used in this product will effectively operate the cooling system down to 0°F when this product is applied in a comfort cooling application for people. An economizer is typically included in this type of application. When applying this product for process cooling applications (computer rooms, switchgear, etc.), please reference applications bulletin AE-011-07 or call the applications department for Unitary Products @ 1-877-UPG-SERV for guidance. Additional accessories may be needed for stable operation at temperatures below 30° F.

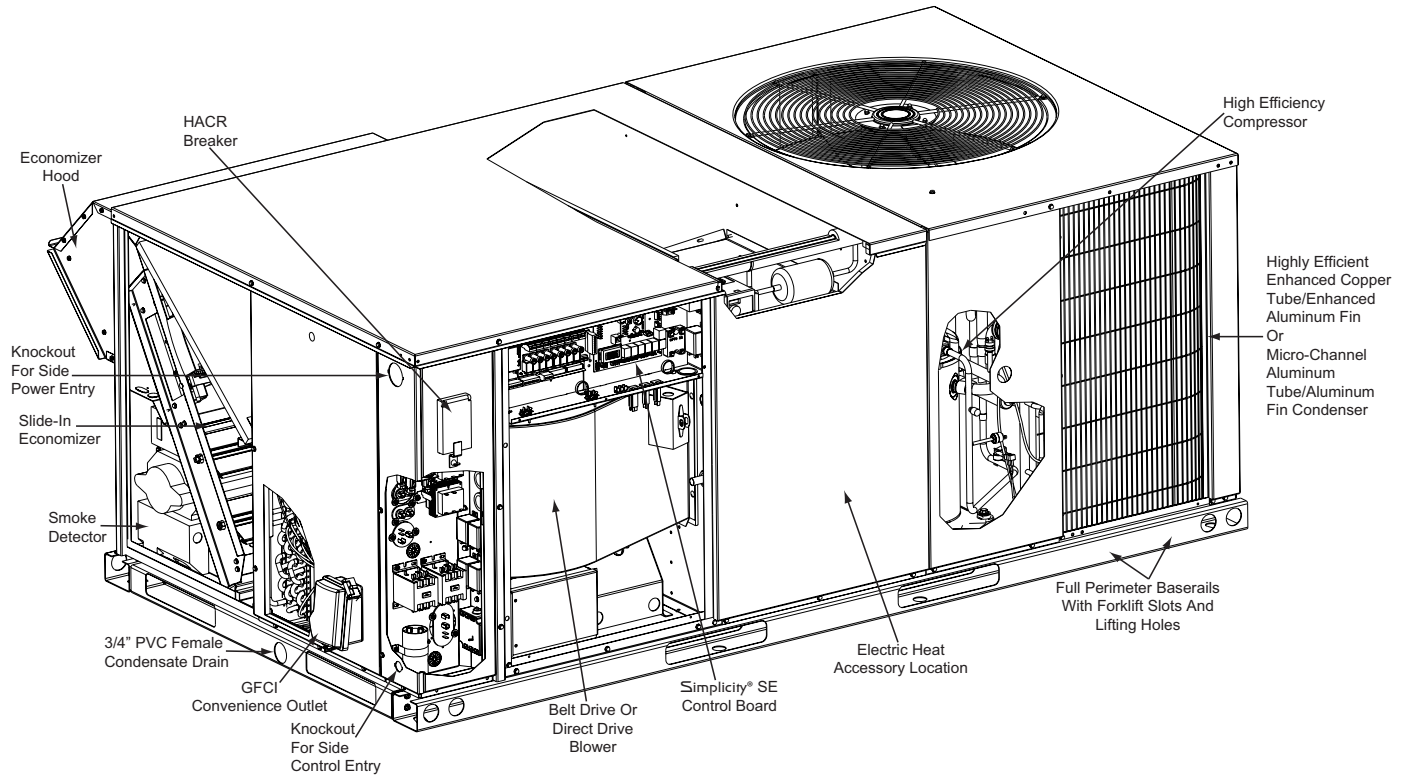

Figure 1: XN036-060 Component Location

Table 1: XN036-060 Unit Limitations

| Size (Tons) | Unit Voltage | Unit Limitations | | |
|-------------|--------------|------------------|-----|-----------------|
| | | Applied Voltage | | Outdoor DB Temp |
| | | Min | Max | Max (°F) |
| 036 (3.0) | 208/230-1-60 | 187 | 252 | 125 |
| | 208/230-3-60 | 187 | 252 | 125 |
| | 460-3-60 | 432 | 504 | 125 |
| | 575-3-60 | 540 | 630 | 125 |
| 048 (4.0) | 208/230-1-60 | 187 | 252 | 125 |
| | 208/230-3-60 | 187 | 252 | 125 |
| | 460-3-60 | 432 | 504 | 125 |
| | 575-3-60 | 540 | 630 | 125 |
| 060 (5.0) | 208/230-1-60 | 187 | 252 | 125 |
| | 208/230-3-60 | 187 | 252 | 125 |
| | 460-3-60 | 432 | 504 | 125 |
| | 575-3-60 | 540 | 630 | 125 |

Location

Use the following guidelines to select a suitable location for these units:

- Unit is designed for *outdoor installation only*.
- Condenser coils must have an unlimited supply of air. Where a choice of location is possible, position the unit on either north or east side of building.
- Suitable for mounting on roof curb.
- For ground level installation, use a level concrete slab with a minimum thickness of 4 inches. The length and width should be at least 6 inches greater than the unit base rails. Do not tie slab to the building foundation.
- Roof structures must be able to support the weight of the unit and its options/accessories. Unit must be installed on a solid, level roof curb or appropriate angle iron frame.
- Maintain level tolerance to 1/2" across the entire width and length of unit.

Clearances

All units require particular clearances for proper operation and service. Installer must make provisions for adequate ventilation air. Refer to Table 4 for clearances required for construction, servicing, and proper unit operation.

WARNING

Do not permit overhanging structures or shrubs to obstruct condenser air discharge outlet.

Rigging And Handling

Exercise care when moving the unit. Do not remove any packaging until the unit is near the place of installation. Rig the unit by attaching chain or cable slings to the lifting holes provided in the base rails. Spreader bars, whose length exceeds the largest dimension across the unit, **MUST** be used across the top of the unit.

CAUTION

If a unit is to be installed on a roof curb other than a York® roof curb, gasketing must be applied to all surfaces that come in contact with the unit underside.

CAUTION

Before lifting, make sure the unit weight is distributed equally on the rigging cables so it will lift evenly.

Units may be moved or lifted with a forklift. Slotted openings in the base rails are provided for this purpose.

LENGTH OF FORKS MUST BE A MINIMUM OF 42 INCHES.

CAUTION

All panels must be secured in place when the unit is lifted.
The condenser coils should be protected from rigging cable damage with plywood or other suitable material.

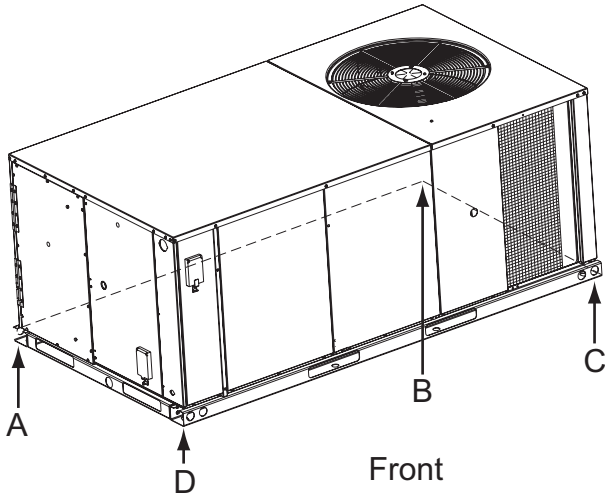

Figure 2: Unit 4 Point Load Weight

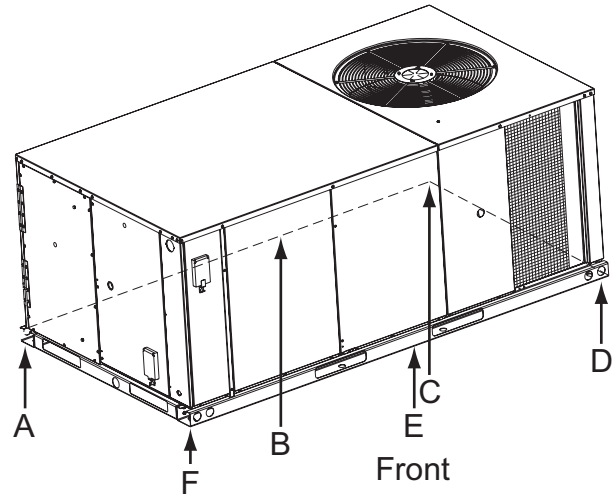

Figure 3: Unit 6 Point Load Weight

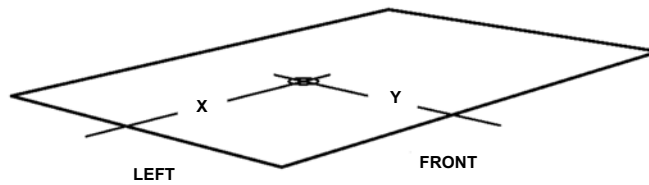

Figure 4: Center of Gravity

Table 2: Weights and Dimensions

| Size (Tons) | Weight (lbs.) | | Center of Gravity | | 4 point Load Location (lbs.) | | | | 6 point Load Location (lbs.) | | | | | |
|-------------|---------------|-----------|-------------------|-------|------------------------------|-----|-----|-----|------------------------------|----|----|-----|-----|-----|
| | Shipping | Operating | X | Y | A | B | C | D | A | B | C | D | E | F |
| 036 (3) | 615 | 610 | 38.3 | 18.75 | 136 | 119 | 165 | 190 | 93 | 85 | 77 | 108 | 118 | 129 |
| 048 (4) | 621 | 616 | 38.2 | 18.4 | 135 | 117 | 169 | 195 | 92 | 84 | 76 | 110 | 121 | 133 |
| 060 (5) | 625 | 620 | 38.6 | 18 | 132 | 117 | 174 | 197 | 90 | 83 | 76 | 114 | 123 | 134 |

Table 3: XN036-060 Unit Accessory Weights

| Unit Accessory | Weight (lbs.) | |
|----------------------------|---------------|-----------|
| | Shipping | Operating |
| Economizer | 55 | 50 |
| Power Exhaust | 55 | 50 |
| Electric Heat ¹ | 28 | 28 |

1. Weight given is for the maximum heater size available (30KW).

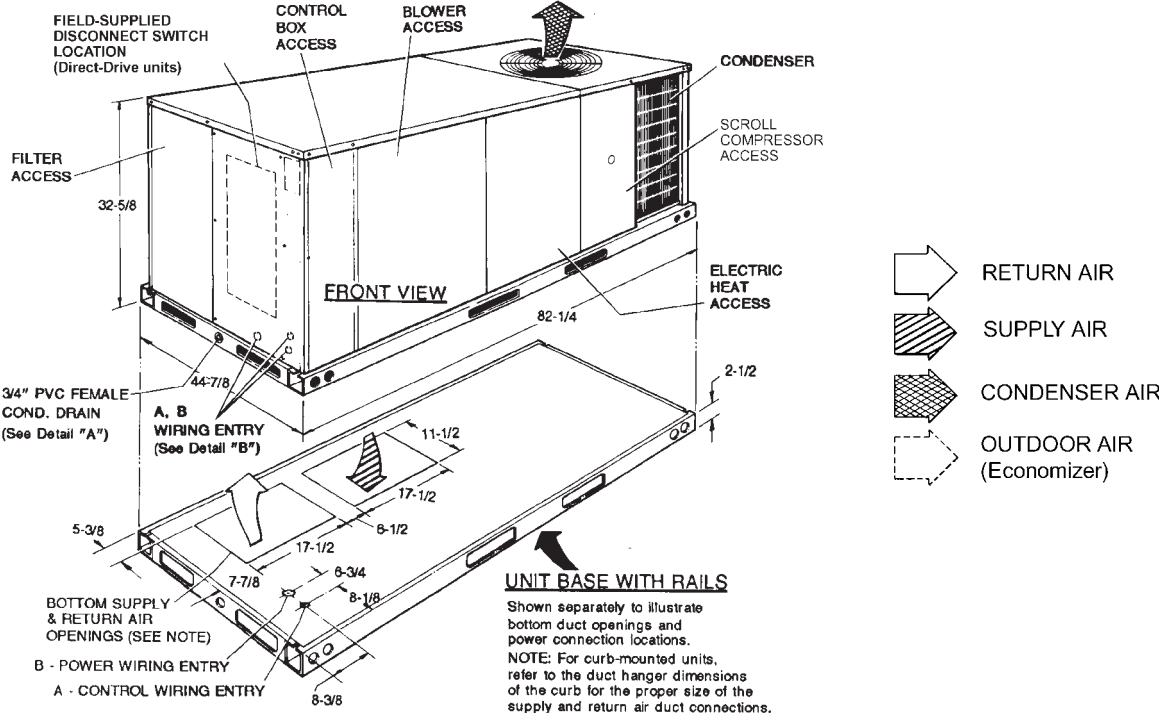

Figure 5: XN036-060 Heat Pump/Electric Heat Front View Physical Dimensions

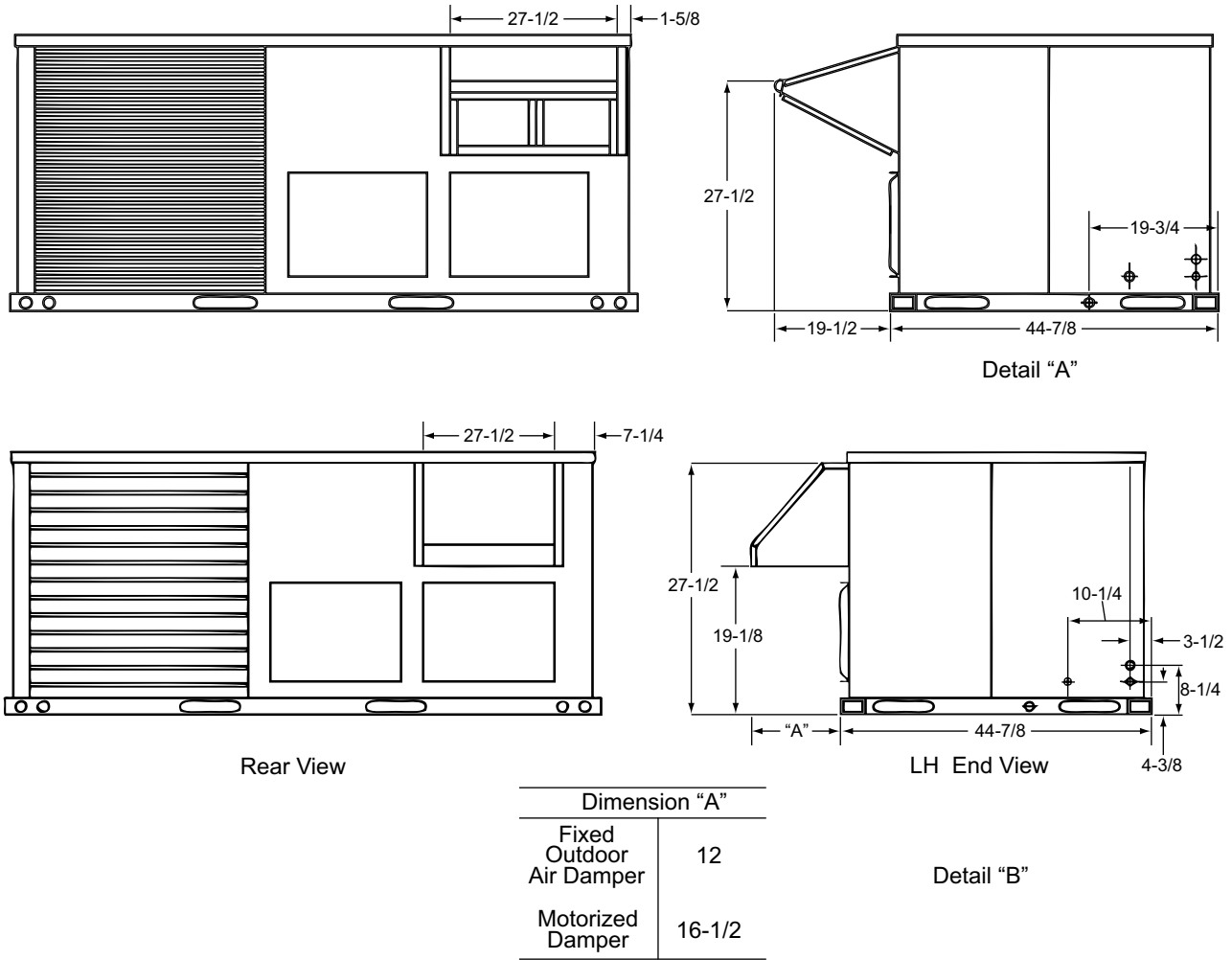

Figure 6: XN036-060 Fixed Outdoor Air Motorized Damper Rain Hood Physical Dimensions

Table 4: XN036-060 Unit Clearances

| Location | Clearance |
|---------------------------|---|
| Front | 24" (Cooling/Electric Heat) |
| Rear | 12" (Less Economizer) |
| | 36" (With Economizer or Fixed Air/Motorized Damper) |
| Left Side (Filter Access) | 24" (Less Economizer) 36" (With Economizer) |
| Right Side (Cond. Coil) | 24" |
| Below Unit ¹ | 0" |
| Above Unit ² | 72" (For Condenser Air Discharge) |

- Units may be installed on combustible floors made from wood or class A, B, or C roof covering material.
- Units must be installed outdoors. Overhanging structures or shrubs should not obstruct condenser air discharge outlet.

NOTE: Units and ductwork are approved for zero clearance to combustible materials when equipped with electric heaters.

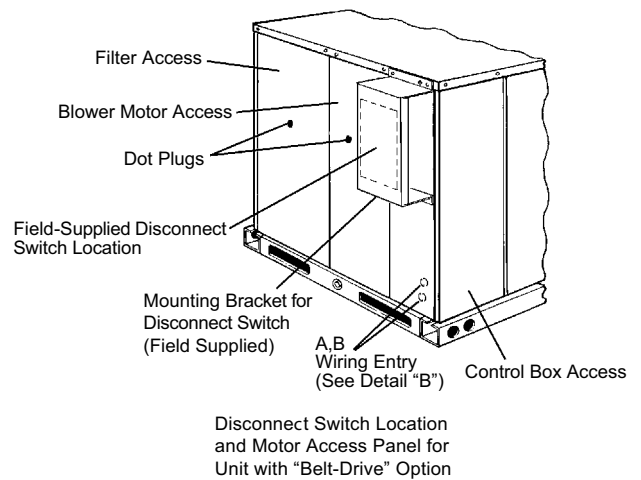
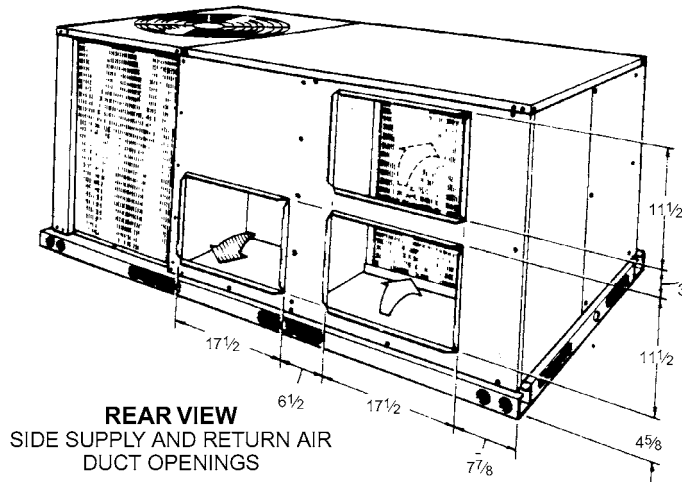

Figure 7: XN036-060 Disconnect Location



REAR VIEW
SIDE SUPPLY AND RETURN AIR
DUCT OPENINGS

DUCT COVERS - Units are shipped with all air duct openings covered.

For side duct applications;

1. Remove and discard the supply and return air duct covers.
2. Connect ductwork to duct flanges on the rear of the unit.

For bottom duct applications;

1. Remove the side supply air duct cover to gain access to the bottom supply air knockout panel.
2. Remove and discard the bottom knockout panel.
3. Replace the side duct cover.
4. With filter section access panel removed from the unit, remove and discard the bottom return air knockout panel.
5. Replace the filter access panel.

Figure 8: XN036-060 Unit Side Duct Openings

Table 5: XN036-060 Utilities Entry

| Hole | Opening Size (Dia.) | Used For |
|------|----------------------|-----------------------------|
| A | 7/8" KO ¹ | Control Wiring |
| | | Side Bottom ² |
| B | 2" KO ¹ | Power Wiring |
| | | Side Bottom |

1. Opening in the bottom to the unit can be located by the slice in the insulation.
2. Do not remove the 2" knockout ring.

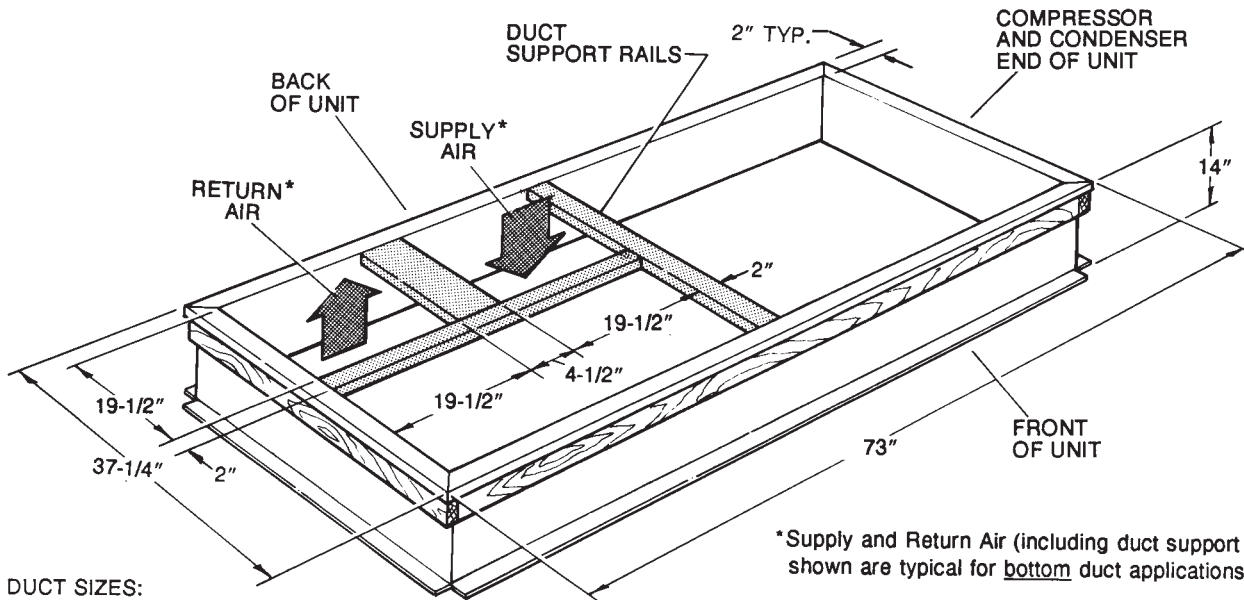

DUCT SIZES:
Supply Air = 19-1/4" X 19-1/4"
Return Air = 19-1/4" X 19-1/4"

*Supply and Return Air (including duct support rails) shown are typical for bottom duct applications.

For location of horizontal duct applications (on back of unit), refer to Unit Dimension details.

Figure 9: XN036-060 Roof Curb

Ductwork

Ductwork should be designed and sized according to the methods in Manual D of the Air Conditioning Contractors of America (ACCA) or as recommended by any other recognized authority such as ASHRAE or SMACNA.

A closed return duct system should be used. This will not preclude use of economizers or outdoor fresh air intake. The supply and return air duct connections at the unit should be made with flexible joints to minimize noise.

The supply and return air duct systems should be designed for the CFM and static pressure requirements of the job. They should NOT be sized to match the dimensions of the duct connections on the unit.

Refer to Figure 5 for bottom air duct openings. Refer to Figure 8 for side air duct openings.

CAUTION

When fastening ductwork to side duct flanges on unit, insert screws through duct flanges only. DO NOT insert screws through casing. Outdoor ductwork must be insulated and water-proofed.

Condensate Drain

Plumbing must conform to local codes. Use a sealing compound on male pipe threads. Install a condensate drain line from the 3/4" PVC female connection on the unit to an open drain.

NOTE: The condensate drain operates in a negative pressure in the cabinet. The condensate drain line MUST be trapped to provide proper drainage. See Figure 10.

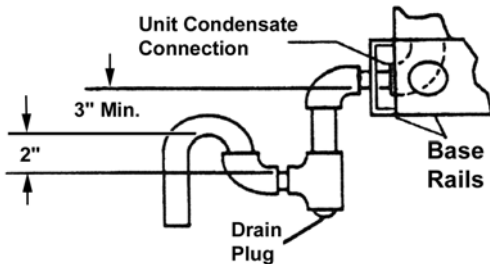

Figure 10: Condensate Drain

Compressors

The scroll compressor used in this product is specifically designed to operate with R-410A Refrigerant and cannot be interchanged.

CAUTION

This system uses R-410A Refrigerant which operates at higher pressures than R-22. No other refrigerant may be used in this system.

The compressor also uses a polyolester (POE oil), Mobil 3MA POE. This oil is extremely hygroscopic, meaning it absorbs water readily. POE oil can absorb 15 times as much water as other oils designed for HCFC and CFC refrigerants. Take all necessary precautions to avoid exposure of the oil to the atmosphere.

CAUTION

Do not leave the system open to the atmosphere. Unit damage could occur due to moisture being absorbed by the **POE oil** in the system. This type of oil is highly susceptible to moisture absorption

POE (polyolester) compressor lubricants are known to cause long term damage to some synthetic roofing materials.

CAUTION

Exposure, even if immediately cleaned up, may cause embrittlement (leading to cracking) to occur in one year or more. When performing any service that may risk exposure of compressor oil to the roof, take precautions to protect roofing.

Procedures which risk oil leakage include, but are not limited to, compressor replacement, repairing refrigerant leaks, replacing refrigerant components such as filter drier, pressure switch, metering device or coil.

Units are shipped with compressor mountings which are factory-adjusted and ready for operation.

Units with scroll compressors have a shipping bracket which must be removed after the unit is set in place. See Figure 11.

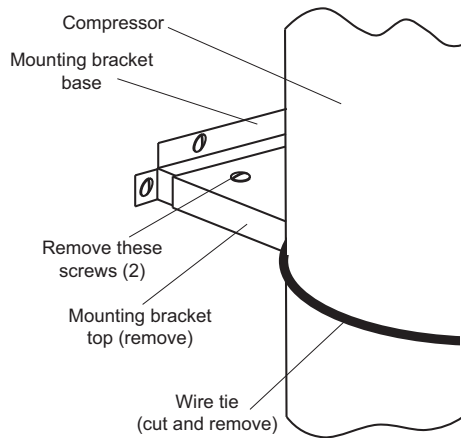

Figure 11: Compressor Restraining Bracket

CAUTION

Do not loosen compressor mounting bolts.

Filters

One or two-inch filters can be supplied with each unit. One-inch filters may be used with no modification to the filter racks. Filters must always be installed ahead of evaporator coil and must be kept clean or replaced with same size and type. Dirty filters reduce the capacity of the unit and result in frosted coils or safety shutdown. Refer to physical data tables, for the number and size of filters needed for the unit. The unit should not be operated without filters properly installed.

CAUTION

Make sure that panel latches are properly positioned on the unit to maintain an airtight seal.

Power And Control Wiring

Field wiring to the unit, fuses, and disconnects must conform to provisions of National Electrical Code (NEC), ANSI/NFPA No. 70 – Latest Edition (in U.S.A.), current Canadian Electrical Code C221, and/or local ordinances. The unit must be electrically grounded in accordance with NEC and CEC as specified above and/or local codes.

Voltage tolerances which must be maintained at the compressor terminals during starting and running conditions are indicated on the unit Rating Plate and Table 1.

CAUTION

208/230-3-60 and 380/415-3-50 units control transformers are factory wired for 230v and 415v power supply respectively. Change tap on transformer for 208-3-60 or 380-3-50 operation. See unit wiring diagram.

The internal wiring harnesses furnished with this unit are an integral part of the design certified unit. Field alteration to comply with electrical codes should not be required. If any of the wire supplied with the unit must be replaced, replacement wire must be of the type shown on the wiring diagram and the same minimum gauge as the replaced wire.

A disconnect must be utilized for these units. Factory installed disconnects are available. If installing a disconnect (field supplied or York International® supplied accessory), refer to Figure 7 for the recommended mounting location.

CAUTION

Avoid damage to internal components if drilling holes for disconnect mounting.

NOTE: Since not all local codes allow the mounting of a disconnect on the unit, please confirm compliance with local code before mounting a disconnect on the unit.

Electrical line must be sized properly to carry the load. USE COPPER CONDUCTORS ONLY. Each unit must be wired with a separate branch circuit fed directly from the meter panel and properly fused.

Refer to Figure 12 for typical field wiring and to the appropriate unit wiring diagram mounted inside control doors for control circuit and power wiring information.

CAUTION

When connecting electrical power and control wiring to the unit, water-proof connectors must be used so that water or moisture cannot be drawn into the unit during normal operation. The above water-proofing conditions will also apply when installing a field supplied disconnect switch.

⚠ CAUTION

When installing equipment in a facility with a 3 phase high-leg delta power supply, care must be taken to ensure that the high-leg conductor is not attached to either of the two legs of the (single phase, direct drive) X13 or ECM motors. Failure to do so can result in the motor acting erratically or not running at all.

Check for the high leg conductor by checking voltage of each phase to ground.

Example: A or L1 phase to ground, voltage reading is 120V. B or L2 phase to ground, voltage reading is 195 to 208V. C or L3 phase to ground, voltage reading is 120V. Therefore B or L2 phase is the high Leg. The high should always be wired to the center or B or L2 tap.

Note: Check all three phase motors and compressors for proper rotation after making a change. If it is necessary to change 3 phase motor rotation, swap A or L1 and C or L3 only.

Power Wiring Detail

Units are factory wired for the voltage shown on the unit nameplate. Refer to Electrical Data Table 7 to size power wiring, fuses, and disconnect switch.

Power wiring is brought into the unit through the side of the unit or the basepan inside the curb.

Thermostat Wiring

The thermostat should be located on an inside wall approximately 56 inch above the floor where it will not be subject to drafts, sun exposure or heat from electrical fixtures or appliances. Follow the manufacturer's instructions enclosed with thermostat for general installation procedure. Seven (7) color-coded, insulated wires should be used to connect the thermostat to the unit. Refer to Table 6 for control wire sizing and maximum length.

Table 6: Control Wire Sizes

| Wire Size | Maximum Length ¹ |
|-----------|-----------------------------|
| 18 AWG | 150 Feet |

1. From the unit to the thermostat and back to the unit.

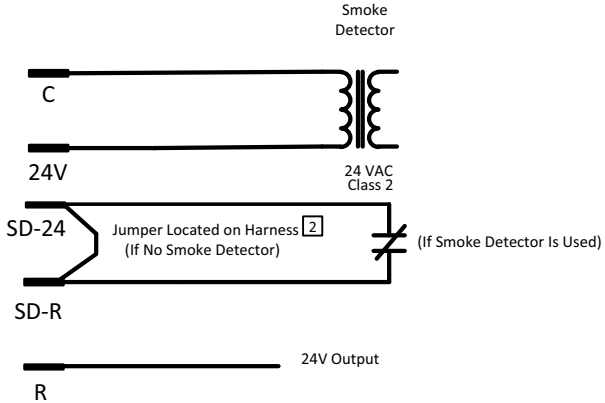
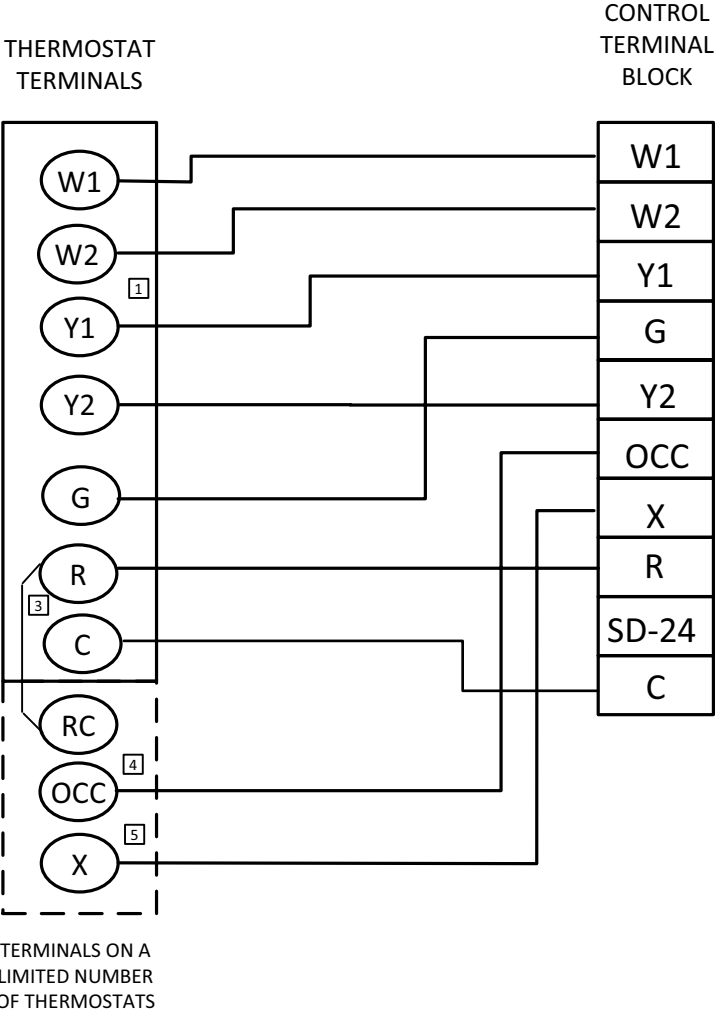

- [1] Second stage heating not required on single stage heating units.
- [2] Jumper is required if there is no Smoke Detector circuit.
- [3] Jumper is required for any combination of R, RC, or RH.
- [4] OCC is an output from the thermostat to indicate the Occupied condition.
- [5] X is an input to the thermostat to display Error Status conditions.

Figure 12: Typical Field Control Wiring

Table 7: Electrical Data

XN036-060 - Without Powered Convenience Outlet (Belt Drive)

| Size (Tons) | Volt | Compressors (each) | | | OD Fan Motors (each) | Supply Blower Motor | Pwr Conv Outlet | Electric Heat Option | | | | MCA ¹ (Amps) | Max Fuse ² / Breaker ³ Size (Amps) |
|-------------|----------|--------------------|------|------|----------------------|---------------------|-----------------|----------------------|------|--------|------|-------------------------|---|
| | | RLA | LRA | MCC | FLA | FLA | FLA | Model | kW | Stages | Amps | | |
| 036 (3.0) | 208-1-60 | 16.7 | 109 | 26 | 1.3 | 6.7 | 0 | NONE | - | - | - | 28.9 | 35 |
| | | | | | | | | E05 | 4 | 1 | 19.2 | 52.9 | 60 |
| | | | | | | | | E07 | 5.6 | 1 | 26.9 | 62.5 | 70 |
| | | | | | | | | E10 | 8 | 1 | 38.5 | 77 | 80 |
| | | | | | | | | E15 | 11.9 | 2 | 57.2 | 100.4 | 110 |
| | | | | | | | | E20 | 15.9 | 2 | 76.4 | 124.4 | 125 |
| | 230-1-60 | 16.7 | 109 | 26 | 1.3 | 6.7 | 0 | NONE | - | - | - | 28.9 | 35 |
| | | | | | | | | E05 | 5.3 | 1 | 22.1 | 56.5 | 60 |
| | | | | | | | | E07 | 7.5 | 1 | 31.2 | 67.9 | 70 |
| | | | | | | | | E10 | 10.6 | 1 | 44.2 | 84.1 | 90 |
| | | | | | | | | E15 | 15.9 | 2 | 66.2 | 111.7 | 125 |
| | | | | | | | | E20 | 21.2 | 2 | 88.3 | 139.3 | 150 |
| | 208-3-60 | 11.2 | 88 | 17.5 | 1.3 | 4.3 | 0 | NONE | - | - | - | 19.6 | 25 |
| | | | | | | | | E05 | 4 | 1 | 11.1 | 33.5 | 40 |
| | | | | | | | | E07 | 5.6 | 1 | 15.5 | 39 | 45 |
| | | | | | | | | E10 | 8 | 1 | 22.2 | 47.4 | 50 |
| | | | | | | | | E15 | 11.9 | 2 | 33 | 60.9 | 70 |
| | | | | | | | | E20 | 15.9 | 2 | 44.1 | 74.8 | 80 |
| | 230-3-60 | 11.2 | 88 | 17.5 | 1.3 | 4.3 | 0 | NONE | - | - | - | 19.6 | 25 |
| | | | | | | | | E05 | 5.3 | 1 | 12.7 | 35.5 | 40 |
| | | | | | | | | E07 | 7.5 | 1 | 18 | 42.2 | 45 |
| | | | | | | | | E10 | 10.6 | 1 | 25.5 | 51.5 | 60 |
| | | | | | | | | E15 | 15.9 | 2 | 38.2 | 67.4 | 70 |
| | | | | | | | | E20 | 21.2 | 2 | 51 | 83.3 | 90 |
| 460-3-60 | 5.5 | 43.2 | 7.7 | 0.8 | 2.1 | 0 | NONE | - | - | - | 9.8 | 15 | |
| | | | | | | | E07 | 6.8 | 1 | 8.2 | 20 | 20 | |
| | | | | | | | E10 | 10.1 | 1 | 12.1 | 25 | 25 | |
| | | | | | | | E15 | 13.6 | 2 | 16.4 | 30.2 | 35 | |
| | | | | | | | E20 | 19.5 | 2 | 23.5 | 39.1 | 40 | |
| 575-3-60 | 3.8 | 34 | 6 | 0.8 | 1.9 | 0 | NONE | - | - | - | 7.3 | 15 | |
| | | | | | | | E10 | 10.6 | 1 | 10.2 | 20 | 25 | |
| | | | | | | | E15 | 15.9 | 2 | 15.3 | 26.4 | 30 | |
| | | | | | | | E20 | 21.2 | 2 | 20.4 | 32.8 | 35 | |
| 048 (4.0) | 208-1-60 | 19.6 | 130 | 30.5 | 2.8 | 6.7 | 0 | NONE | - | - | - | 34 | 45 |
| | | | | | | | | E05 | 4 | 1 | 19.2 | 58 | 70 |
| | | | | | | | | E07 | 5.6 | 1 | 26.9 | 67.7 | 80 |
| | | | | | | | | E10 | 8 | 1 | 38.5 | 82.1 | 90 |
| | | | | | | | | E15 | 11.9 | 2 | 57.2 | 105.5 | 110 |
| | | | | | | | | E20 | 15.9 | 2 | 76.4 | 129.6 | 150 |
| | 230-1-60 | 19.6 | 130 | 30.5 | 2.8 | 6.7 | 0 | NONE | - | - | - | 34 | 45 |
| | | | | | | | | E05 | 5.3 | 1 | 22.1 | 61.6 | 70 |
| | | | | | | | | E07 | 7.5 | 1 | 31.2 | 73.1 | 80 |
| | | | | | | | | E10 | 10.6 | 1 | 44.2 | 89.2 | 90 |
| | | | | | | | | E15 | 15.9 | 2 | 66.2 | 116.8 | 125 |
| | | | | | | | | E20 | 21.2 | 2 | 88.3 | 144.4 | 150 |
| | 208-3-60 | 13.7 | 83.1 | 21.4 | 2.8 | 4.3 | 0 | NONE | - | - | - | 24.2 | 30 |
| | | | | | | | | E05 | 4 | 1 | 11.1 | 38.1 | 45 |
| | | | | | | | | E07 | 5.6 | 1 | 15.5 | 43.7 | 50 |
| | | | | | | | | E10 | 8 | 1 | 22.2 | 52 | 60 |
| | | | | | | | | E15 | 11.9 | 2 | 33 | 65.5 | 70 |
| | | | | | | | | E20 | 15.9 | 2 | 44.1 | 79.4 | 80 |
| | 230-3-60 | 13.7 | 83.1 | 21.4 | 2.8 | 4.3 | 0 | NONE | - | - | - | 24.2 | 30 |
| | | | | | | | | E05 | 5.3 | 1 | 12.7 | 40.2 | 50 |
| | | | | | | | | E07 | 7.5 | 1 | 18 | 46.8 | 50 |
| | | | | | | | | E10 | 10.6 | 1 | 25.5 | 56.1 | 60 |
| | | | | | | | | E15 | 15.9 | 2 | 38.2 | 72 | 80 |
| | | | | | | | | E20 | 21.2 | 2 | 51 | 88 | 90 |
| 460-3-60 | 6.2 | 41 | 9.7 | 2.8 | 2.1 | 0 | NONE | - | - | - | 11.3 | 15 | |
| | | | | | | | E07 | 6.8 | 1 | 8.2 | 21.5 | 25 | |
| | | | | | | | E10 | 10.1 | 1 | 12.1 | 26.4 | 30 | |
| | | | | | | | E15 | 13.6 | 2 | 16.4 | 31.7 | 35 | |
| 575-3-60 | 4.8 | 33 | 7.5 | 2.8 | 1.9 | 0 | NONE | - | - | - | 9 | 15 | |
| | | | | | | | E10 | 10.6 | 1 | 10.2 | 21.8 | 25 | |
| | | | | | | | E15 | 15.9 | 2 | 15.3 | 28.1 | 30 | |
| | | | | | | | E20 | 21.2 | 2 | 20.4 | 34.5 | 35 | |

XN036-060 - Without Powered Convenience Outlet (Belt Drive) (Continued)

| Size (Tons) | Volt | Compressors (each) | | | OD Fan Motors (each) | Supply Blower Motor | Pwr Conv Outlet | Electric Heat Option | | | | MCA ¹ (Amps) | Max Fuse ² / Breaker ³ Size (Amps) |
|----------------|----------|-----------------------|-------|------|----------------------------|---------------------------|-----------------------|----------------------|------|--------|------|----------------------------|--|
| | | RLA | LRA | MCC | FLA | FLA | FLA | Model | kW | Stages | Amps | | |
| 060 (5.0) | 208-1-60 | 27.1 | 152.9 | 42.3 | 2.8 | 4.3 | 0 | NONE | - | - | - | 41 | 50 |
| | | | | | | | | E05 | 4 | 1 | 19.2 | 65 | 80 |
| | | | | | | | | E07 | 5.6 | 1 | 26.9 | 74.6 | 90 |
| | | | | | | | | E10 | 8 | 1 | 38.5 | 89.1 | 100 |
| | | | | | | | | E15 | 11.9 | 2 | 57.2 | 112.5 | 125 |
| | | | | | | | | E20 | 15.9 | 2 | 76.4 | 136.5 | 150 |
| | 230-1-60 | 27.1 | 152.9 | 42.3 | 2.8 | 4.3 | 0 | NONE | - | - | - | 41 | 50 |
| | | | | | | | | E05 | 5.3 | 1 | 22.1 | 68.6 | 90 |
| | | | | | | | | E07 | 7.5 | 1 | 31.2 | 80 | 90 |
| | | | | | | | | E10 | 10.6 | 1 | 44.2 | 96.2 | 110 |
| | | | | | | | | E15 | 15.9 | 2 | 66.2 | 123.8 | 125 |
| | | | | | | | | E20 | 21.2 | 2 | 88.3 | 151.4 | 175 |
| | 208-3-60 | 16.5 | 110 | 25.8 | 2.8 | 4.3 | 0 | NONE | - | - | - | 27.7 | 35 |
| | | | | | | | | E05 | 4 | 1 | 11.1 | 41.6 | 50 |
| | | | | | | | | E07 | 5.6 | 1 | 15.5 | 47.2 | 50 |
| | | | | | | | | E10 | 8 | 1 | 22.2 | 55.5 | 60 |
| | | | | | | | | E15 | 11.9 | 2 | 33 | 69 | 70 |
| | | | | | | | | E20 | 15.9 | 2 | 44.1 | 82.9 | 90 |
| | 230-3-60 | 16.5 | 110 | 25.8 | 2.8 | 4.3 | 0 | NONE | - | - | - | 27.7 | 35 |
| | | | | | | | | E05 | 5.3 | 1 | 12.7 | 43.7 | 50 |
| | | | | | | | | E07 | 7.5 | 1 | 18 | 50.3 | 60 |
| | | | | | | | | E10 | 10.6 | 1 | 25.5 | 59.6 | 60 |
| | | | | | | | | E15 | 15.9 | 2 | 38.2 | 75.5 | 80 |
| | | | | | | | | E20 | 21.2 | 2 | 51 | 91.5 | 100 |
| | 460-3-60 | 7.2 | 52 | 11.3 | 2.8 | 2.1 | 0 | NONE | - | - | - | 12.5 | 15 |
| | | | | | | | | E07 | 6.8 | 1 | 8.2 | 22.7 | 25 |
| | | | | | | | | E10 | 10.1 | 1 | 12.1 | 27.7 | 30 |
| | | | | | | | | E15 | 13.6 | 2 | 16.4 | 32.9 | 35 |
| E20 | | | | | | | | 19.5 | 2 | 23.5 | 41.8 | 45 | |
| E30 | | | | | | | | 28.8 | 2 | 34.6 | 55.8 | 60 | |
| 575-3-60 | 5.5 | 38.9 | 8.6 | 2.8 | 1.9 | 0 | NONE | - | - | - | 9.9 | 15 | |
| | | | | | | | E10 | 10.6 | 1 | 10.2 | 22.6 | 25 | |
| | | | | | | | E15 | 15.9 | 2 | 15.3 | 29 | 30 | |
| | | | | | | | E20 | 21.2 | 2 | 20.4 | 35.4 | 40 | |
| | | | | | | | E30 | 30.4 | 2 | 29.3 | 46.5 | 50 | |

1. Minimum Circuit Ampacity.
2. Dual Element, Time Delay Type.
3. HACR type per NEC.

XN036-060 Without Powered Convenience Outlet (Belt Drive High Static)

| Size (Tons) | Volt | Compressors (each) | | | OD Fan Motors (each) | Supply Blower Motor | Pwr Conv Outlet | Electric Heat Option | | | | MCA ¹ (Amps) | Max Fuse ² / Breaker ³ Size (Amps) |
|--------------|----------|--------------------|------|------|----------------------|---------------------|-----------------|----------------------|------|--------|------|-------------------------|---|
| | | RLA | LRA | MCC | FLA | FLA | FLA | Model | kW | Stages | Amps | | |
| 036 (3.0) | 208-1-60 | 16.7 | 109 | 26 | 1.3 | 6.7 | 0 | NONE | - | - | - | 28.9 | 35 |
| | | | | | | | | E05 | 4 | 1 | 19.2 | 52.9 | 60 |
| | | | | | | | | E07 | 5.6 | 1 | 26.9 | 62.5 | 70 |
| | | | | | | | | E10 | 8 | 1 | 38.5 | 77 | 80 |
| | | | | | | | | E15 | 11.9 | 2 | 57.2 | 100.4 | 110 |
| | | | | | | | | E20 | 15.9 | 2 | 76.4 | 124.4 | 125 |
| | 230-1-60 | 16.7 | 109 | 26 | 1.3 | 6.7 | 0 | NONE | - | - | - | 28.9 | 35 |
| | | | | | | | | E05 | 5.3 | 1 | 22.1 | 56.5 | 60 |
| | | | | | | | | E07 | 7.5 | 1 | 31.2 | 67.9 | 70 |
| | | | | | | | | E10 | 10.6 | 1 | 44.2 | 84.1 | 90 |
| | | | | | | | | E15 | 15.9 | 2 | 66.2 | 111.7 | 125 |
| | | | | | | | | E20 | 21.2 | 2 | 88.3 | 139.3 | 150 |
| | 208-3-60 | 11.2 | 88 | 17.5 | 1.3 | 4.3 | 0 | NONE | - | - | - | 19.6 | 25 |
| | | | | | | | | E05 | 4 | 1 | 11.1 | 33.5 | 40 |
| | | | | | | | | E07 | 5.6 | 1 | 15.5 | 39 | 45 |
| | | | | | | | | E10 | 8 | 1 | 22.2 | 47.4 | 50 |
| | | | | | | | | E15 | 11.9 | 2 | 33 | 60.9 | 70 |
| | | | | | | | | E20 | 15.9 | 2 | 44.1 | 74.8 | 80 |
| | 230-3-60 | 11.2 | 88 | 17.5 | 1.3 | 4.3 | 0 | NONE | - | - | - | 19.6 | 25 |
| | | | | | | | | E05 | 5.3 | 1 | 12.7 | 35.5 | 40 |
| | | | | | | | | E07 | 7.5 | 1 | 18 | 42.2 | 45 |
| | | | | | | | | E10 | 10.6 | 1 | 25.5 | 51.5 | 60 |
| | | | | | | | | E15 | 15.9 | 2 | 38.2 | 67.4 | 70 |
| | | | | | | | | E20 | 21.2 | 2 | 51 | 83.3 | 90 |
| 460-3-60 | 5.5 | 43.2 | 7.7 | 0.8 | 2.1 | 0 | NONE | - | - | - | 9.8 | 15 | |
| | | | | | | | E07 | 6.8 | 1 | 8.2 | 20 | 20 | |
| | | | | | | | E10 | 10.1 | 1 | 12.1 | 25 | 25 | |
| | | | | | | | E15 | 13.6 | 2 | 16.4 | 30.2 | 35 | |
| | | | | | | | E20 | 19.5 | 2 | 23.5 | 39.1 | 40 | |
| | | | | | | | 575-3-60 | 3.8 | 34 | 6 | 0.8 | 1.9 | 0 |
| E10 | 10.6 | 1 | 10.2 | 20 | 25 | | | | | | | | |
| E15 | 15.9 | 2 | 15.3 | 26.4 | 30 | | | | | | | | |
| E20 | 21.2 | 2 | 20.4 | 32.8 | 35 | | | | | | | | |
| 048 (4.0) | 208-1-60 | 19.6 | 130 | 30.5 | 2.8 | 6.7 | 0 | NONE | - | - | - | 34 | 45 |
| | | | | | | | | E05 | 4 | 1 | 19.2 | 58 | 70 |
| | | | | | | | | E07 | 5.6 | 1 | 26.9 | 67.7 | 80 |
| | | | | | | | | E10 | 8 | 1 | 38.5 | 82.1 | 90 |
| | | | | | | | | E15 | 11.9 | 2 | 57.2 | 105.5 | 110 |
| | | | | | | | | E20 | 15.9 | 2 | 76.4 | 129.6 | 150 |
| | 230-1-60 | 19.6 | 130 | 30.5 | 2.8 | 6.7 | 0 | NONE | - | - | - | 34 | 45 |
| | | | | | | | | E05 | 5.3 | 1 | 22.1 | 61.6 | 70 |
| | | | | | | | | E07 | 7.5 | 1 | 31.2 | 73.1 | 80 |
| | | | | | | | | E10 | 10.6 | 1 | 44.2 | 89.2 | 90 |
| | | | | | | | | E15 | 15.9 | 2 | 66.2 | 116.8 | 125 |
| | | | | | | | | E20 | 21.2 | 2 | 88.3 | 144.4 | 150 |
| | 208-3-60 | 13.7 | 83.1 | 21.4 | 2.8 | 4.3 | 0 | NONE | - | - | - | 24.2 | 30 |
| | | | | | | | | E05 | 4 | 1 | 11.1 | 38.1 | 45 |
| | | | | | | | | E07 | 5.6 | 1 | 15.5 | 43.7 | 50 |
| | | | | | | | | E10 | 8 | 1 | 22.2 | 52 | 60 |
| | | | | | | | | E15 | 11.9 | 2 | 33 | 65.5 | 70 |
| | | | | | | | | E20 | 15.9 | 2 | 44.1 | 79.4 | 80 |
| | 230-3-60 | 13.7 | 83.1 | 21.4 | 2.8 | 4.3 | 0 | NONE | - | - | - | 24.2 | 30 |
| | | | | | | | | E05 | 5.3 | 1 | 12.7 | 40.2 | 50 |
| | | | | | | | | E07 | 7.5 | 1 | 18 | 46.8 | 50 |
| | | | | | | | | E10 | 10.6 | 1 | 25.5 | 56.1 | 60 |
| | | | | | | | | E15 | 15.9 | 2 | 38.2 | 72 | 80 |
| | | | | | | | | E20 | 21.2 | 2 | 51 | 88 | 90 |
| 460-3-60 | 6.2 | 41 | 9.7 | 2.8 | 2.1 | 0 | NONE | - | - | - | 11.3 | 15 | |
| | | | | | | | E07 | 6.8 | 1 | 8.2 | 21.5 | 25 | |
| | | | | | | | E10 | 10.1 | 1 | 12.1 | 26.4 | 30 | |
| | | | | | | | E15 | 13.6 | 2 | 16.4 | 31.7 | 35 | |
| | | | | | | | E20 | 19.5 | 2 | 23.5 | 40.6 | 45 | |
| | | | | | | | 575-3-60 | 4.8 | 33 | 7.5 | 2.8 | 1.9 | 0 |
| E10 | 10.6 | 1 | 10.2 | 21.8 | 25 | | | | | | | | |
| E15 | 15.9 | 2 | 15.3 | 28.1 | 30 | | | | | | | | |
| E20 | 21.2 | 2 | 20.4 | 34.5 | 35 | | | | | | | | |

XN036-060 Without Powered Convenience Outlet (Belt Drive High Static) (Continued)

| Size (Tons) | Volt | Compressors (each) | | | OD Fan Motors (each) | Supply Blower Motor | Pwr Conv Outlet | Electric Heat Option | | | | MCA ¹ (Amps) | Max Fuse ² / Breaker ³ Size (Amps) |
|----------------|----------|-----------------------|------|------|----------------------------|---------------------------|-----------------------|----------------------|------|--------|------|----------------------------|--|
| | | RLA | LRA | MCC | FLA | FLA | FLA | Model | kW | Stages | Amps | | |
| 060 (5.0) | 208-3-60 | 16.5 | 110 | 25.8 | 2.8 | 6.8 | 0 | NONE | - | - | - | 30.2 | 40 |
| | | | | | | | | E05 | 4 | 1 | 11.1 | 44.1 | 50 |
| | | | | | | | | E07 | 5.6 | 1 | 15.5 | 49.7 | 60 |
| | | | | | | | | E10 | 8 | 1 | 22.2 | 58 | 60 |
| | | | | | | | | E15 | 11.9 | 2 | 33 | 71.5 | 80 |
| | | | | | | | | E20 | 15.9 | 2 | 44.1 | 85.4 | 90 |
| | 230-3-60 | 16.5 | 110 | 25.8 | 2.8 | 6.8 | 0 | NONE | - | - | - | 30.2 | 40 |
| | | | | | | | | E05 | 5.3 | 1 | 12.7 | 46.2 | 50 |
| | | | | | | | | E07 | 7.5 | 1 | 18 | 52.8 | 60 |
| | | | | | | | | E10 | 10.6 | 1 | 25.5 | 62.1 | 70 |
| | | | | | | | | E15 | 15.9 | 2 | 38.2 | 78 | 80 |
| | | | | | | | | E20 | 21.2 | 2 | 51 | 94 | 100 |
| | 460-3-60 | 7.2 | 52 | 11.3 | 2.8 | 3.15 | 0 | NONE | - | - | - | 13.6 | 20 |
| | | | | | | | | E07 | 6.8 | 1 | 8.2 | 23.8 | 25 |
| | | | | | | | | E10 | 10.1 | 1 | 12.1 | 28.7 | 30 |
| | | | | | | | | E15 | 13.6 | 2 | 16.4 | 34 | 35 |
| | | | | | | | | E20 | 19.5 | 2 | 23.5 | 42.9 | 45 |
| | | | | | | | | E30 | 28.8 | 2 | 34.6 | 56.9 | 60 |
| | 575-3-60 | 5.5 | 38.9 | 8.6 | 2.8 | 2.2 | 0 | NONE | - | - | - | 10.2 | 15 |
| | | | | | | | | E10 | 10.6 | 1 | 10.2 | 22.9 | 25 |
| | | | | | | | | E15 | 15.9 | 2 | 15.3 | 29.3 | 30 |
| | | | | | | | | E20 | 21.2 | 2 | 20.4 | 35.7 | 40 |
| | | | | | | | | E30 | 30.4 | 2 | 29.3 | 46.8 | 50 |

1. Minimum Circuit Ampacity.
2. Dual Element, Time Delay Type.
3. HACR type per NEC.

XN036-060 - Without Powered Convenience Outlet (Direct Drive)

| Size (Tons) | Volt | Compressors (each) | | | OD Fan Motors (each) | Supply Blower Motor | Pwr Conv Outlet | Electric Heat Option | | | | MCA ¹ (Amps) | Max Fuse ² / Breaker ³ Size (Amps) |
|--------------|----------|--------------------|------|------|----------------------|---------------------|-----------------|----------------------|------|--------|------|-------------------------|---|
| | | RLA | LRA | MCC | FLA | FLA | FLA | Model | kW | Stages | Amps | | |
| 036 (3.0) | 208-1-60 | 16.7 | 109 | 26 | 1.3 | 6 | 0 | NONE | - | - | - | 28.2 | 35 |
| | | | | | | | | E05 | 4 | 1 | 19.2 | 52.2 | 60 |
| | | | | | | | | E07 | 5.6 | 1 | 26.9 | 61.8 | 70 |
| | | | | | | | | E10 | 8 | 1 | 38.5 | 76.3 | 80 |
| | | | | | | | | E15 | 11.9 | 2 | 57.2 | 99.7 | 100 |
| | | | | | | | | E20 | 15.9 | 2 | 76.4 | 123.7 | 125 |
| | 230-1-60 | 16.7 | 109 | 26 | 1.3 | 6 | 0 | NONE | - | - | - | 28.2 | 35 |
| | | | | | | | | E05 | 5.3 | 1 | 22.1 | 55.8 | 60 |
| | | | | | | | | E07 | 7.5 | 1 | 31.2 | 67.2 | 70 |
| | | | | | | | | E10 | 10.6 | 1 | 44.2 | 83.4 | 90 |
| | | | | | | | | E15 | 15.9 | 2 | 66.2 | 111 | 125 |
| | | | | | | | | E20 | 21.2 | 2 | 88.3 | 138.6 | 150 |
| | 208-3-60 | 11.2 | 88 | 17.5 | 1.3 | 6 | 0 | NONE | - | - | - | 21.3 | 30 |
| | | | | | | | | E05 | 4 | 1 | 11.1 | 35.2 | 40 |
| | | | | | | | | E07 | 5.6 | 1 | 15.5 | 40.7 | 45 |
| | | | | | | | | E10 | 8 | 1 | 22.2 | 49.1 | 50 |
| | | | | | | | | E15 | 11.9 | 2 | 33 | 62.6 | 70 |
| | | | | | | | | E20 | 15.9 | 2 | 44.1 | 76.5 | 80 |
| | 230-3-60 | 11.2 | 88 | 17.5 | 1.3 | 6 | 0 | NONE | - | - | - | 21.3 | 30 |
| | | | | | | | | E05 | 5.3 | 1 | 12.7 | 37.2 | 45 |
| E07 | | | | | | | | 7.5 | 1 | 18 | 43.9 | 50 | |
| E10 | | | | | | | | 10.6 | 1 | 25.5 | 53.2 | 60 | |
| E15 | | | | | | | | 15.9 | 2 | 38.2 | 69.1 | 70 | |
| E20 | | | | | | | | 21.2 | 2 | 51 | 85 | 90 | |
| 048 (4.0) | 208-1-60 | 19.6 | 130 | 30.5 | 2.8 | 7.6 | 0 | NONE | - | - | - | 34.9 | 45 |
| | | | | | | | | E05 | 4 | 1 | 19.2 | 58.9 | 70 |
| | | | | | | | | E07 | 5.6 | 1 | 26.9 | 68.6 | 80 |
| | | | | | | | | E10 | 8 | 1 | 38.5 | 83 | 90 |
| | | | | | | | | E15 | 11.9 | 2 | 57.2 | 106.4 | 110 |
| | | | | | | | | E20 | 15.9 | 2 | 76.4 | 130.5 | 150 |
| | 230-1-60 | 19.6 | 130 | 30.5 | 2.8 | 7.6 | 0 | NONE | - | - | - | 34.9 | 45 |
| | | | | | | | | E05 | 5.3 | 1 | 22.1 | 62.5 | 70 |
| | | | | | | | | E07 | 7.5 | 1 | 31.2 | 74 | 80 |
| | | | | | | | | E10 | 10.6 | 1 | 44.2 | 90.1 | 100 |
| | | | | | | | | E15 | 15.9 | 2 | 66.2 | 117.7 | 125 |
| | | | | | | | | E20 | 21.2 | 2 | 88.3 | 145.3 | 150 |
| | 208-3-60 | 13.7 | 83.1 | 21.4 | 2.8 | 7.6 | 0 | NONE | - | - | - | 27.5 | 35 |
| | | | | | | | | E05 | 4 | 1 | 11.1 | 41.4 | 50 |
| | | | | | | | | E07 | 5.6 | 1 | 15.5 | 47 | 50 |
| | | | | | | | | E10 | 8 | 1 | 22.2 | 55.3 | 60 |
| | | | | | | | | E15 | 11.9 | 2 | 33 | 68.8 | 70 |
| | | | | | | | | E20 | 15.9 | 2 | 44.1 | 82.7 | 90 |
| | 230-3-60 | 13.7 | 83.1 | 21.4 | 2.8 | 7.6 | 0 | NONE | - | - | - | 27.5 | 35 |
| | | | | | | | | E05 | 5.3 | 1 | 12.7 | 43.5 | 50 |
| E07 | | | | | | | | 7.5 | 1 | 18 | 50.1 | 60 | |
| E10 | | | | | | | | 10.6 | 1 | 25.5 | 59.4 | 60 | |
| E15 | | | | | | | | 15.9 | 2 | 38.2 | 75.3 | 80 | |
| E20 | | | | | | | | 21.2 | 2 | 51 | 91.3 | 100 | |

XN036-060 - Without Powered Convenience Outlet (Direct Drive) (Continued)

| Size (Tons) | Volt | Compressors (each) | | | OD Fan Motors (each) | Supply Blower Motor | Pwr Conv Outlet | Electric Heat Option | | | | MCA ¹ (Amps) | Max Fuse ² / Breaker ³ Size (Amps) |
|----------------|----------|-----------------------|-------|------|----------------------------|---------------------------|-----------------------|----------------------|------|--------|------|----------------------------|--|
| | | RLA | LRA | MCC | FLA | FLA | FLA | Model | kW | Stages | Amps | | |
| 060 (5.0) | 208-1-60 | 27.1 | 152.9 | 42.3 | 2.8 | 7.6 | 0 | NONE | - | - | - | 44.3 | 60 |
| | | | | | | | | E05 | 4 | 1 | 19.2 | 68.3 | 90 |
| | | | | | | | | E07 | 5.6 | 1 | 26.9 | 77.9 | 90 |
| | | | | | | | | E10 | 8 | 1 | 38.5 | 92.4 | 100 |
| | | | | | | | | E15 | 11.9 | 2 | 57.2 | 115.8 | 125 |
| | | | | | | | | E20 | 15.9 | 2 | 76.4 | 139.8 | 150 |
| | 230-1-60 | 27.1 | 152.9 | 42.3 | 2.8 | 7.6 | 0 | NONE | - | - | - | 44.3 | 60 |
| | | | | | | | | E05 | 5.3 | 1 | 22.1 | 71.9 | 90 |
| | | | | | | | | E07 | 7.5 | 1 | 31.2 | 83.3 | 100 |
| | | | | | | | | E10 | 10.6 | 1 | 44.2 | 99.5 | 110 |
| | | | | | | | | E15 | 15.9 | 2 | 66.2 | 127.1 | 150 |
| | | | | | | | | E20 | 21.2 | 2 | 88.3 | 154.7 | 175 |
| | 208-3-60 | 16.5 | 110 | 25.8 | 2.8 | 7.6 | 0 | NONE | - | - | - | 31 | 40 |
| | | | | | | | | E05 | 4 | 1 | 11.1 | 44.9 | 50 |
| | | | | | | | | E07 | 5.6 | 1 | 15.5 | 50.5 | 60 |
| | | | | | | | | E10 | 8 | 1 | 22.2 | 58.8 | 60 |
| | | | | | | | | E15 | 11.9 | 2 | 33 | 72.3 | 80 |
| | | | | | | | | E20 | 15.9 | 2 | 44.1 | 86.2 | 90 |
| | 230-3-60 | 16.5 | 110 | 25.8 | 2.8 | 7.6 | 0 | NONE | - | - | - | 31 | 40 |
| | | | | | | | | E05 | 5.3 | 1 | 12.7 | 47 | 60 |
| | | | | | | | | E07 | 7.5 | 1 | 18 | 53.6 | 60 |
| | | | | | | | | E10 | 10.6 | 1 | 25.5 | 62.9 | 70 |
| | | | | | | | | E15 | 15.9 | 2 | 38.2 | 78.8 | 80 |
| | | | | | | | | E20 | 21.2 | 2 | 51 | 94.8 | 100 |
| | | | | | | | E30 | 29.6 | 2 | 71.2 | 120 | 125 | |

1. Minimum Circuit Ampacity.
2. Dual Element, Time Delay Type.
3. HACR type per NEC.

XN036-060 - With Powered Convenience Outlet (Belt Drive)

| Size (Tons) | Volt | Compressors (each) | | | OD Fan Motors (each) | Supply Blower Motor | Pwr Conv Outlet | Electric Heat Option | | | | MCA ¹ (Amps) | Max Fuse ² / Breaker ³ Size (Amps) |
|--------------|----------|--------------------|------|------|----------------------|---------------------|-----------------|----------------------|------|--------|------|-------------------------|---|
| | | RLA | LRA | MCC | FLA | FLA | FLA | Model | kW | Stages | Amps | | |
| 036 (3.0) | 208-1-60 | 16.7 | 109 | 26 | 1.3 | 6.7 | 10 | NONE | - | - | - | 38.9 | 50 |
| | | | | | | | | E05 | 4 | 1 | 19.2 | 62.9 | 70 |
| | | | | | | | | E07 | 5.6 | 1 | 26.9 | 72.5 | 80 |
| | | | | | | | | E10 | 8 | 1 | 38.5 | 87 | 90 |
| | | | | | | | | E15 | 11.9 | 2 | 57.2 | 110.4 | 125 |
| | | | | | | | | E20 | 15.9 | 2 | 76.4 | 134.4 | 150 |
| | 230-1-60 | 16.7 | 109 | 26 | 1.3 | 6.7 | 10 | NONE | - | - | - | 38.9 | 50 |
| | | | | | | | | E05 | 5.3 | 1 | 22.1 | 66.5 | 70 |
| | | | | | | | | E07 | 7.5 | 1 | 31.2 | 77.9 | 80 |
| | | | | | | | | E10 | 10.6 | 1 | 44.2 | 94.1 | 100 |
| | | | | | | | | E15 | 15.9 | 2 | 66.2 | 121.7 | 125 |
| | | | | | | | | E20 | 21.2 | 2 | 88.3 | 149.3 | 150 |
| | 208-3-60 | 11.2 | 88 | 17.5 | 1.3 | 4.3 | 10 | NONE | - | - | - | 29.6 | 40 |
| | | | | | | | | E05 | 4 | 1 | 11.1 | 43.5 | 50 |
| | | | | | | | | E07 | 5.6 | 1 | 15.5 | 49 | 50 |
| | | | | | | | | E10 | 8 | 1 | 22.2 | 57.4 | 60 |
| | | | | | | | | E15 | 11.9 | 2 | 33 | 70.9 | 80 |
| | | | | | | | | E20 | 15.9 | 2 | 44.1 | 84.8 | 90 |
| | 230-3-60 | 11.2 | 88 | 17.5 | 1.3 | 4.3 | 10 | NONE | - | - | - | 29.6 | 40 |
| | | | | | | | | E05 | 5.3 | 1 | 12.7 | 45.5 | 50 |
| | | | | | | | | E07 | 7.5 | 1 | 18 | 52.2 | 60 |
| | | | | | | | | E10 | 10.6 | 1 | 25.5 | 61.5 | 70 |
| | | | | | | | | E15 | 15.9 | 2 | 38.2 | 77.4 | 80 |
| | | | | | | | | E20 | 21.2 | 2 | 51 | 93.3 | 100 |
| 460-3-60 | 5.5 | 43.2 | 7.7 | 0.8 | 2.1 | 5 | NONE | - | - | - | 14.8 | 20 | |
| | | | | | | | E07 | 6.8 | 1 | 8.2 | 25 | 25 | |
| | | | | | | | E10 | 10.1 | 1 | 12.1 | 30 | 30 | |
| | | | | | | | E15 | 13.6 | 2 | 16.4 | 35.2 | 40 | |
| | | | | | | | E20 | 19.5 | 2 | 23.5 | 44.1 | 45 | |
| | | | | | | | | | | | | | |
| 575-3-60 | 3.8 | 34 | 6 | 0.8 | 1.9 | 4 | E10 | 10.6 | 1 | 10.2 | 24.1 | 25 | |
| | | | | | | | E15 | 15.9 | 2 | 15.3 | 30.5 | 35 | |
| | | | | | | | E20 | 21.2 | 2 | 20.4 | 36.8 | 40 | |
| | | | | | | | NONE | - | - | - | 44 | 60 | |
| | | | | | | | E05 | 4 | 1 | 19.2 | 68 | 80 | |
| | | | | | | | E07 | 5.6 | 1 | 26.9 | 77.7 | 90 | |
| 048 (4.0) | 208-1-60 | 19.6 | 130 | 30.5 | 2.8 | 6.7 | 10 | NONE | - | - | - | 44 | 60 |
| | | | | | | | | E05 | 4 | 1 | 19.2 | 68 | 80 |
| | | | | | | | | E07 | 5.6 | 1 | 26.9 | 77.7 | 90 |
| | | | | | | | | E10 | 8 | 1 | 38.5 | 92.1 | 100 |
| | | | | | | | | E15 | 11.9 | 2 | 57.2 | 115.5 | 125 |
| | | | | | | | | E20 | 15.9 | 2 | 76.4 | 139.6 | 150 |
| | 230-1-60 | 19.6 | 130 | 30.5 | 2.8 | 6.7 | 10 | NONE | - | - | - | 44 | 60 |
| | | | | | | | | E05 | 5.3 | 1 | 22.1 | 71.6 | 80 |
| | | | | | | | | E07 | 7.5 | 1 | 31.2 | 83.1 | 90 |
| | | | | | | | | E10 | 10.6 | 1 | 44.2 | 99.2 | 100 |
| | | | | | | | | E15 | 15.9 | 2 | 66.2 | 126.8 | 150 |
| | | | | | | | | E20 | 21.2 | 2 | 88.3 | 154.4 | 175 |
| | 208-3-60 | 13.7 | 83.1 | 21.4 | 2.8 | 4.3 | 10 | NONE | - | - | - | 34.2 | 45 |
| | | | | | | | | E05 | 4 | 1 | 11.1 | 48.1 | 50 |
| | | | | | | | | E07 | 5.6 | 1 | 15.5 | 53.7 | 60 |
| | | | | | | | | E10 | 8 | 1 | 22.2 | 62 | 70 |
| | | | | | | | | E15 | 11.9 | 2 | 33 | 75.5 | 80 |
| | | | | | | | | E20 | 15.9 | 2 | 44.1 | 89.4 | 90 |
| | 230-3-60 | 13.7 | 83.1 | 21.4 | 2.8 | 4.3 | 10 | NONE | - | - | - | 34.2 | 45 |
| | | | | | | | | E05 | 5.3 | 1 | 12.7 | 50.2 | 60 |
| | | | | | | | | E07 | 7.5 | 1 | 18 | 56.8 | 60 |
| | | | | | | | | E10 | 10.6 | 1 | 25.5 | 66.1 | 70 |
| | | | | | | | | E15 | 15.9 | 2 | 38.2 | 82 | 90 |
| | | | | | | | | E20 | 21.2 | 2 | 51 | 98 | 100 |
| 460-3-60 | 6.2 | 41 | 9.7 | 2.8 | 2.1 | 5 | NONE | - | - | - | 16.3 | 20 | |
| | | | | | | | E07 | 6.8 | 1 | 8.2 | 26.5 | 30 | |
| | | | | | | | E10 | 10.1 | 1 | 12.1 | 31.4 | 35 | |
| | | | | | | | E15 | 13.6 | 2 | 16.4 | 36.7 | 40 | |
| | | | | | | | E20 | 19.5 | 2 | 23.5 | 45.6 | 50 | |
| | | | | | | | | | | | | | |
| 575-3-60 | 4.8 | 33 | 7.5 | 2.8 | 1.9 | 4 | E10 | 10.6 | 1 | 10.2 | 25.8 | 30 | |
| | | | | | | | E15 | 15.9 | 2 | 15.3 | 32.1 | 35 | |
| | | | | | | | E20 | 21.2 | 2 | 20.4 | 38.5 | 40 | |

XN036-060 - With Powered Convenience Outlet (Belt Drive) (Continued)

| Size (Tons) | Volt | Compressors (each) | | | OD Fan Motors (each) | Supply Blower Motor | Pwr Conv Outlet | Electric Heat Option | | | | MCA ¹ (Amps) | Max Fuse ^{2/} Breaker ³ Size (Amps) |
|----------------|----------|-----------------------|-------|------|----------------------------|---------------------------|-----------------------|----------------------|------|--------|-------|----------------------------|--|
| | | RLA | LRA | MCC | FLA | FLA | FLA | Model | kW | Stages | Amps | | |
| 060 (5.0) | 208-1-60 | 27.1 | 152.9 | 42.3 | 2.8 | 4.3 | 10 | NONE | - | - | - | 51 | 70 |
| | | | | | | | | E05 | 4 | 1 | 19.2 | 75 | 90 |
| | | | | | | | | E07 | 5.6 | 1 | 26.9 | 84.6 | 100 |
| | | | | | | | | E10 | 8 | 1 | 38.5 | 99.1 | 110 |
| | | | | | | | | E15 | 11.9 | 2 | 57.2 | 122.5 | 125 |
| | | | | | | | | E20 | 15.9 | 2 | 76.4 | 146.5 | 150 |
| | | | | | | | | E30 | 22.2 | 2 | 106.7 | 184.4 | 200 |
| | 230-1-60 | 27.1 | 152.9 | 42.3 | 2.8 | 4.3 | 10 | NONE | - | - | - | 51 | 70 |
| | | | | | | | | E05 | 5.3 | 1 | 22.1 | 78.6 | 100 |
| | | | | | | | | E07 | 7.5 | 1 | 31.2 | 90 | 100 |
| | | | | | | | | E10 | 10.6 | 1 | 44.2 | 106.2 | 110 |
| | | | | | | | | E15 | 15.9 | 2 | 66.2 | 133.8 | 150 |
| | | | | | | | | E20 | 21.2 | 2 | 88.3 | 161.4 | 175 |
| | | | | | | | | E30 | 29.6 | 2 | 123.3 | 205.1 | 225 |
| | 208-3-60 | 16.5 | 110 | 25.8 | 2.8 | 4.3 | 10 | NONE | - | - | - | 37.7 | 50 |
| | | | | | | | | E05 | 4 | 1 | 11.1 | 51.6 | 60 |
| | | | | | | | | E07 | 5.6 | 1 | 15.5 | 57.2 | 60 |
| | | | | | | | | E10 | 8 | 1 | 22.2 | 65.5 | 70 |
| | | | | | | | | E15 | 11.9 | 2 | 33 | 79 | 80 |
| | | | | | | | | E20 | 15.9 | 2 | 44.1 | 92.9 | 100 |
| | | | | | | | | E30 | 22.2 | 2 | 61.6 | 114.8 | 125 |
| | 230-3-60 | 16.5 | 110 | 25.8 | 2.8 | 4.3 | 10 | NONE | - | - | - | 37.7 | 50 |
| | | | | | | | | E05 | 5.3 | 1 | 12.7 | 53.7 | 60 |
| | | | | | | | | E07 | 7.5 | 1 | 18 | 60.3 | 70 |
| | | | | | | | | E10 | 10.6 | 1 | 25.5 | 69.6 | 70 |
| | | | | | | | | E15 | 15.9 | 2 | 38.2 | 85.5 | 90 |
| | | | | | | | | E20 | 21.2 | 2 | 51 | 101.5 | 110 |
| | | | | | | | | E30 | 29.6 | 2 | 71.2 | 126.7 | 150 |
| 460-3-60 | 7.2 | 52 | 11.3 | 2.8 | 2.1 | 5 | NONE | - | - | - | 17.5 | 20 | |
| | | | | | | | E07 | 6.8 | 1 | 8.2 | 27.7 | 30 | |
| | | | | | | | E10 | 10.1 | 1 | 12.1 | 32.7 | 35 | |
| | | | | | | | E15 | 13.6 | 2 | 16.4 | 37.9 | 40 | |
| | | | | | | | E20 | 19.5 | 2 | 23.5 | 46.8 | 50 | |
| | | | | | | | E30 | 28.8 | 2 | 34.6 | 60.8 | 70 | |
| 575-3-60 | 5.5 | 38.9 | 8.6 | 2.8 | 1.9 | 4 | NONE | - | - | - | 13.9 | 15 | |
| | | | | | | | E10 | 10.6 | 1 | 10.2 | 26.6 | 30 | |
| | | | | | | | E15 | 15.9 | 2 | 15.3 | 33 | 35 | |
| | | | | | | | E20 | 21.2 | 2 | 20.4 | 39.4 | 40 | |
| | | | | | | | E30 | 30.4 | 2 | 29.3 | 50.5 | 60 | |

1. Minimum Circuit Ampacity.
2. Dual Element, Time Delay Type.
3. HACR type per NEC.

XN036-060 With Powered Convenience Outlet (Belt Drive High Static)

| Size (Tons) | Volt | Compressors (each) | | | OD Fan Motors (each) | Supply Blower Motor | Pwr Conv Outlet | Electric Heat Option | | | | MCA ¹ (Amps) | Max Fuse ² / Breaker ³ Size (Amps) |
|--------------|----------|--------------------|------|------|----------------------|---------------------|-----------------|----------------------|------|--------|------|-------------------------|---|
| | | RLA | LRA | MCC | FLA | FLA | FLA | Model | kW | Stages | Amps | | |
| 036 (3.0) | 208-1-60 | 16.7 | 109 | 26 | 1.3 | 6.7 | 10 | NONE | - | - | - | 38.9 | 50 |
| | | | | | | | | E05 | 4 | 1 | 19.2 | 62.9 | 70 |
| | | | | | | | | E07 | 5.6 | 1 | 26.9 | 72.5 | 80 |
| | | | | | | | | E10 | 8 | 1 | 38.5 | 87 | 90 |
| | | | | | | | | E15 | 11.9 | 2 | 57.2 | 110.4 | 125 |
| | | | | | | | | E20 | 15.9 | 2 | 76.4 | 134.4 | 150 |
| | 230-1-60 | 16.7 | 109 | 26 | 1.3 | 6.7 | 10 | NONE | - | - | - | 38.9 | 50 |
| | | | | | | | | E05 | 5.3 | 1 | 22.1 | 66.5 | 70 |
| | | | | | | | | E07 | 7.5 | 1 | 31.2 | 77.9 | 80 |
| | | | | | | | | E10 | 10.6 | 1 | 44.2 | 94.1 | 100 |
| | | | | | | | | E15 | 15.9 | 2 | 66.2 | 121.7 | 125 |
| | | | | | | | | E20 | 21.2 | 2 | 88.3 | 149.3 | 150 |
| | 208-3-60 | 11.2 | 88 | 17.5 | 1.3 | 4.3 | 10 | NONE | - | - | - | 29.6 | 40 |
| | | | | | | | | E05 | 4 | 1 | 11.1 | 43.5 | 50 |
| | | | | | | | | E07 | 5.6 | 1 | 15.5 | 49 | 50 |
| | | | | | | | | E10 | 8 | 1 | 22.2 | 57.4 | 60 |
| | | | | | | | | E15 | 11.9 | 2 | 33 | 70.9 | 80 |
| | | | | | | | | E20 | 15.9 | 2 | 44.1 | 84.8 | 90 |
| | 230-3-60 | 11.2 | 88 | 17.5 | 1.3 | 4.3 | 10 | NONE | - | - | - | 29.6 | 40 |
| | | | | | | | | E05 | 5.3 | 1 | 12.7 | 45.5 | 50 |
| | | | | | | | | E07 | 7.5 | 1 | 18 | 52.2 | 60 |
| | | | | | | | | E10 | 10.6 | 1 | 25.5 | 61.5 | 70 |
| | | | | | | | | E15 | 15.9 | 2 | 38.2 | 77.4 | 80 |
| | | | | | | | | E20 | 21.2 | 2 | 51 | 93.3 | 100 |
| 460-3-60 | 5.5 | 43.2 | 7.7 | 0.8 | 2.1 | 5 | NONE | - | - | - | 14.8 | 20 | |
| | | | | | | | E07 | 6.8 | 1 | 8.2 | 25 | 25 | |
| | | | | | | | E10 | 10.1 | 1 | 12.1 | 30 | 30 | |
| | | | | | | | E15 | 13.6 | 2 | 16.4 | 35.2 | 40 | |
| | | | | | | | E20 | 19.5 | 2 | 23.5 | 44.1 | 45 | |
| 575-3-60 | 3.8 | 34 | 6 | 0.8 | 1.9 | 4 | NONE | - | - | - | 11.3 | 15 | |
| | | | | | | | E10 | 10.6 | 1 | 10.2 | 24.1 | 25 | |
| | | | | | | | E15 | 15.9 | 2 | 15.3 | 30.5 | 35 | |
| | | | | | | | E20 | 21.2 | 2 | 20.4 | 36.8 | 40 | |
| 048 (4.0) | 208-1-60 | 19.6 | 130 | 30.5 | 2.8 | 6.7 | 10 | NONE | - | - | - | 44 | 60 |
| | | | | | | | | E05 | 4 | 1 | 19.2 | 68 | 80 |
| | | | | | | | | E07 | 5.6 | 1 | 26.9 | 77.7 | 90 |
| | | | | | | | | E10 | 8 | 1 | 38.5 | 92.1 | 100 |
| | | | | | | | | E15 | 11.9 | 2 | 57.2 | 115.5 | 125 |
| | | | | | | | | E20 | 15.9 | 2 | 76.4 | 139.6 | 150 |
| | 230-1-60 | 19.6 | 130 | 30.5 | 2.8 | 6.7 | 10 | NONE | - | - | - | 44 | 60 |
| | | | | | | | | E05 | 5.3 | 1 | 22.1 | 71.6 | 80 |
| | | | | | | | | E07 | 7.5 | 1 | 31.2 | 83.1 | 90 |
| | | | | | | | | E10 | 10.6 | 1 | 44.2 | 99.2 | 100 |
| | | | | | | | | E15 | 15.9 | 2 | 66.2 | 126.8 | 150 |
| | | | | | | | | E20 | 21.2 | 2 | 88.3 | 154.4 | 175 |
| | 208-3-60 | 13.7 | 83.1 | 21.4 | 2.8 | 4.3 | 10 | NONE | - | - | - | 34.2 | 45 |
| | | | | | | | | E05 | 4 | 1 | 11.1 | 48.1 | 50 |
| | | | | | | | | E07 | 5.6 | 1 | 15.5 | 53.7 | 60 |
| | | | | | | | | E10 | 8 | 1 | 22.2 | 62 | 70 |
| | | | | | | | | E15 | 11.9 | 2 | 33 | 75.5 | 80 |
| | | | | | | | | E20 | 15.9 | 2 | 44.1 | 89.4 | 90 |
| | 230-3-60 | 13.7 | 83.1 | 21.4 | 2.8 | 4.3 | 10 | NONE | - | - | - | 34.2 | 45 |
| | | | | | | | | E05 | 5.3 | 1 | 12.7 | 50.2 | 60 |
| | | | | | | | | E07 | 7.5 | 1 | 18 | 56.8 | 60 |
| | | | | | | | | E10 | 10.6 | 1 | 25.5 | 66.1 | 70 |
| | | | | | | | | E15 | 15.9 | 2 | 38.2 | 82 | 90 |
| | | | | | | | | E20 | 21.2 | 2 | 51 | 98 | 100 |
| 460-3-60 | 6.2 | 41 | 9.7 | 2.8 | 2.1 | 5 | NONE | - | - | - | 16.3 | 20 | |
| | | | | | | | E07 | 6.8 | 1 | 8.2 | 26.5 | 30 | |
| | | | | | | | E10 | 10.1 | 1 | 12.1 | 31.4 | 35 | |
| | | | | | | | E15 | 13.6 | 2 | 16.4 | 36.7 | 40 | |
| | | | | | | | E20 | 19.5 | 2 | 23.5 | 45.6 | 50 | |
| 575-3-60 | 4.8 | 33 | 7.5 | 2.8 | 1.9 | 4 | NONE | - | - | - | 13 | 15 | |
| | | | | | | | E10 | 10.6 | 1 | 10.2 | 25.8 | 30 | |
| | | | | | | | E15 | 15.9 | 2 | 15.3 | 32.1 | 35 | |
| | | | | | | | E20 | 21.2 | 2 | 20.4 | 38.5 | 40 | |

XN036-060 With Powered Convenience Outlet (Belt Drive High Static) (Continued)

| Size (Tons) | Volt | Compressors (each) | | | OD Fan Motors (each) | Supply Blower Motor | Pwr Conv Outlet | Electric Heat Option | | | | MCA ¹ (Amps) | Max Fuse ^{2/} Breaker ³ Size (Amps) |
|----------------|----------|-----------------------|------|------|----------------------------|---------------------------|-----------------------|----------------------|------|--------|------|----------------------------|--|
| | | RLA | LRA | MCC | FLA | FLA | FLA | Model | kW | Stages | Amps | | |
| 060 (5.0) | 208-3-60 | 16.5 | 110 | 25.8 | 2.8 | 6.8 | 10 | NONE | - | - | - | 40.2 | 50 |
| | | | | | | | | E05 | 4 | 1 | 11.1 | 54.1 | 60 |
| | | | | | | | | E07 | 5.6 | 1 | 15.5 | 59.7 | 70 |
| | | | | | | | | E10 | 8 | 1 | 22.2 | 68 | 70 |
| | | | | | | | | E15 | 11.9 | 2 | 33 | 81.5 | 90 |
| | | | | | | | | E20 | 15.9 | 2 | 44.1 | 95.4 | 100 |
| | 230-3-60 | 16.5 | 110 | 25.8 | 2.8 | 6.8 | 10 | NONE | - | - | - | 40.2 | 50 |
| | | | | | | | | E05 | 5.3 | 1 | 12.7 | 56.2 | 60 |
| | | | | | | | | E07 | 7.5 | 1 | 18 | 62.8 | 70 |
| | | | | | | | | E10 | 10.6 | 1 | 25.5 | 72.1 | 80 |
| | | | | | | | | E15 | 15.9 | 2 | 38.2 | 88 | 90 |
| | | | | | | | | E20 | 21.2 | 2 | 51 | 104 | 110 |
| | 460-3-60 | 7.2 | 52 | 11.3 | 2.8 | 3.15 | 5 | NONE | - | - | - | 18.5 | 25 |
| | | | | | | | | E07 | 6.8 | 1 | 8.2 | 28.8 | 30 |
| | | | | | | | | E10 | 10.1 | 1 | 12.1 | 33.7 | 35 |
| | | | | | | | | E15 | 13.6 | 2 | 16.4 | 39 | 40 |
| | | | | | | | | E20 | 19.5 | 2 | 23.5 | 47.9 | 50 |
| | | | | | | | | E30 | 28.8 | 2 | 34.6 | 61.9 | 70 |
| | 575-3-60 | 5.5 | 38.9 | 8.6 | 2.8 | 2.2 | 4 | NONE | - | - | - | 14.2 | 15 |
| | | | | | | | | E10 | 10.6 | 1 | 10.2 | 26.9 | 30 |
| | | | | | | | | E15 | 15.9 | 2 | 15.3 | 33.3 | 35 |
| | | | | | | | | E20 | 21.2 | 2 | 20.4 | 39.7 | 40 |
| | | | | | | | | E30 | 30.4 | 2 | 29.3 | 50.8 | 60 |

1. Minimum Circuit Ampacity.
2. Dual Element, Time Delay Type.
3. HACR type per NEC.

XN036-060 - With Powered Convenience Outlet (Direct Drive)

| Size (Tons) | Volt | Compressors (each) | | | OD Fan Motors (each) | Supply Blower Motor | Pwr Conv Outlet | Electric Heat Option | | | | MCA ¹ (Amps) | Max Fuse ² / Breaker ³ Size (Amps) |
|--------------|----------|--------------------|------|------|----------------------|---------------------|-----------------|----------------------|------|--------|------|-------------------------|---|
| | | RLA | LRA | MCC | FLA | FLA | FLA | Model | kW | Stages | Amps | | |
| 036 (3.0) | 208-1-60 | 16.7 | 109 | 26 | 1.3 | 6 | 10 | NONE | - | - | - | 38.2 | 50 |
| | | | | | | | | E05 | 4 | 1 | 19.2 | 62.2 | 70 |
| | | | | | | | | E07 | 5.6 | 1 | 26.9 | 71.8 | 80 |
| | | | | | | | | E10 | 8 | 1 | 38.5 | 86.3 | 90 |
| | | | | | | | | E15 | 11.9 | 2 | 57.2 | 109.7 | 110 |
| | | | | | | | | E20 | 15.9 | 2 | 76.4 | 133.7 | 150 |
| | 230-1-60 | 16.7 | 109 | 26 | 1.3 | 6 | 10 | NONE | - | - | - | 38.2 | 50 |
| | | | | | | | | E05 | 5.3 | 1 | 22.1 | 65.8 | 70 |
| | | | | | | | | E07 | 7.5 | 1 | 31.2 | 77.2 | 80 |
| | | | | | | | | E10 | 10.6 | 1 | 44.2 | 93.4 | 100 |
| | | | | | | | | E15 | 15.9 | 2 | 66.2 | 121 | 125 |
| | | | | | | | | E20 | 21.2 | 2 | 88.3 | 148.6 | 150 |
| | 208-3-60 | 11.2 | 88 | 17.5 | 1.3 | 6 | 10 | NONE | - | - | - | 31.3 | 40 |
| | | | | | | | | E05 | 4 | 1 | 11.1 | 45.2 | 50 |
| | | | | | | | | E07 | 5.6 | 1 | 15.5 | 50.7 | 60 |
| | | | | | | | | E10 | 8 | 1 | 22.2 | 59.1 | 60 |
| | | | | | | | | E15 | 11.9 | 2 | 33 | 72.6 | 80 |
| | | | | | | | | E20 | 15.9 | 2 | 44.1 | 86.5 | 90 |
| | 230-3-60 | 11.2 | 88 | 17.5 | 1.3 | 6 | 10 | NONE | - | - | - | 31.3 | 40 |
| | | | | | | | | E05 | 5.3 | 1 | 12.7 | 47.2 | 50 |
| | | | | | | | | E07 | 7.5 | 1 | 18 | 53.9 | 60 |
| | | | | | | | | E10 | 10.6 | 1 | 25.5 | 63.2 | 70 |
| | | | | | | | | E15 | 15.9 | 2 | 38.2 | 79.1 | 80 |
| | | | | | | | | E20 | 21.2 | 2 | 51 | 95 | 100 |
| 048 (4.0) | 208-1-60 | 19.6 | 130 | 30.5 | 2.8 | 7.6 | 10 | NONE | - | - | - | 44.9 | 60 |
| | | | | | | | | E05 | 4 | 1 | 19.2 | 68.9 | 80 |
| | | | | | | | | E07 | 5.6 | 1 | 26.9 | 78.6 | 90 |
| | | | | | | | | E10 | 8 | 1 | 38.5 | 93 | 100 |
| | | | | | | | | E15 | 11.9 | 2 | 57.2 | 116.4 | 125 |
| | | | | | | | | E20 | 15.9 | 2 | 76.4 | 140.5 | 150 |
| | 230-1-60 | 19.6 | 130 | 30.5 | 2.8 | 7.6 | 10 | NONE | - | - | - | 44.9 | 60 |
| | | | | | | | | E05 | 5.3 | 1 | 22.1 | 72.5 | 80 |
| | | | | | | | | E07 | 7.5 | 1 | 31.2 | 84 | 90 |
| | | | | | | | | E10 | 10.6 | 1 | 44.2 | 100.1 | 110 |
| | | | | | | | | E15 | 15.9 | 2 | 66.2 | 127.7 | 150 |
| | | | | | | | | E20 | 21.2 | 2 | 88.3 | 155.3 | 175 |
| | 208-3-60 | 13.7 | 83.1 | 21.4 | 2.8 | 7.6 | 10 | NONE | - | - | - | 37.5 | 50 |
| | | | | | | | | E05 | 4 | 1 | 11.1 | 51.4 | 60 |
| | | | | | | | | E07 | 5.6 | 1 | 15.5 | 57 | 60 |
| | | | | | | | | E10 | 8 | 1 | 22.2 | 65.3 | 70 |
| | | | | | | | | E15 | 11.9 | 2 | 33 | 78.8 | 80 |
| | | | | | | | | E20 | 15.9 | 2 | 44.1 | 92.7 | 100 |
| | 230-3-60 | 13.7 | 83.1 | 21.4 | 2.8 | 7.6 | 10 | NONE | - | - | - | 37.5 | 50 |
| | | | | | | | | E05 | 5.3 | 1 | 12.7 | 53.5 | 60 |
| | | | | | | | | E07 | 7.5 | 1 | 18 | 60.1 | 70 |
| | | | | | | | | E10 | 10.6 | 1 | 25.5 | 69.4 | 70 |
| | | | | | | | | E15 | 15.9 | 2 | 38.2 | 85.3 | 90 |
| | | | | | | | | E20 | 21.2 | 2 | 51 | 101.3 | 110 |

XN036-060 - With Powered Convenience Outlet (Direct Drive) (Continued)

| Size (Tons) | Volt | Compressors (each) | | | OD Fan Motors (each) | Supply Blower Motor | Pwr Conv Outlet | Electric Heat Option | | | | MCA ¹ (Amps) | Max Fuse ² / Breaker ³ Size (Amps) |
|----------------|----------|-----------------------|-------|-------|----------------------------|---------------------------|-----------------------|----------------------|------|--------|-------|----------------------------|--|
| | | RLA | LRA | MCC | FLA | FLA | FLA | Model | kW | Stages | Amps | | |
| 060 (5.0) | 208-1-60 | 27.1 | 152.9 | 42.3 | 2.8 | 7.6 | 10 | NONE | - | - | - | 54.3 | 70 |
| | | | | | | | | E05 | 4 | 1 | 19.2 | 78.3 | 100 |
| | | | | | | | | E07 | 5.6 | 1 | 26.9 | 87.9 | 100 |
| | | | | | | | | E10 | 8 | 1 | 38.5 | 102.4 | 110 |
| | | | | | | | | E15 | 11.9 | 2 | 57.2 | 125.8 | 150 |
| | | | | | | | | E20 | 15.9 | 2 | 76.4 | 149.8 | 150 |
| | E30 | 22.2 | 2 | 106.7 | 187.7 | 200 | | | | | | | |
| | 230-1-60 | 27.1 | 152.9 | 42.3 | 2.8 | 7.6 | 10 | NONE | - | - | - | 54.3 | 70 |
| | | | | | | | | E05 | 5.3 | 1 | 22.1 | 81.9 | 100 |
| | | | | | | | | E07 | 7.5 | 1 | 31.2 | 93.3 | 110 |
| | | | | | | | | E10 | 10.6 | 1 | 44.2 | 109.5 | 125 |
| | | | | | | | | E15 | 15.9 | 2 | 66.2 | 137.1 | 150 |
| | | | | | | | | E20 | 21.2 | 2 | 88.3 | 164.7 | 175 |
| | E30 | 29.6 | 2 | 123.3 | 208.4 | 225 | | | | | | | |
| | 208-3-60 | 16.5 | 110 | 25.8 | 2.8 | 7.6 | 10 | NONE | - | - | - | 41 | 50 |
| | | | | | | | | E05 | 4 | 1 | 11.1 | 54.9 | 60 |
| | | | | | | | | E07 | 5.6 | 1 | 15.5 | 60.5 | 70 |
| | | | | | | | | E10 | 8 | 1 | 22.2 | 68.8 | 70 |
| | | | | | | | | E15 | 11.9 | 2 | 33 | 82.3 | 90 |
| | | | | | | | | E20 | 15.9 | 2 | 44.1 | 96.2 | 100 |
| | E30 | 22.2 | 2 | 61.6 | 118.1 | 125 | | | | | | | |
| | 230-3-60 | 16.5 | 110 | 25.8 | 2.8 | 7.6 | 10 | NONE | - | - | - | 41 | 50 |
| | | | | | | | | E05 | 5.3 | 1 | 12.7 | 57 | 70 |
| | | | | | | | | E07 | 7.5 | 1 | 18 | 63.6 | 70 |
| E10 | | | | | | | | 10.6 | 1 | 25.5 | 72.9 | 80 | |
| E15 | | | | | | | | 15.9 | 2 | 38.2 | 88.8 | 90 | |
| E20 | | | | | | | | 21.2 | 2 | 51 | 104.8 | 110 | |
| E30 | 29.6 | 2 | 71.2 | 130 | 150 | | | | | | | | |

1. Minimum Circuit Ampacity.
2. Dual Element, Time Delay Type.
3. HACR type per NEC.

Table 8: XN036-060 Physical Data

| Component | Models | | |
|-------------------------------------|------------------|------------------|---------------------|
| | XN036 | XN048 | XN060 |
| Nominal Tonnage | 3.0 | 4.0 | 5.0 |
| AHRI COOLING PERFORMANCE | | | |
| Gross Capacity @ AHRI A point (Btu) | 38,400 | 48,700 | 57,500 |
| AHRI net capacity (MBH) | 37,000 | 47,000 | 55,400 |
| EER | 12.0 | 11.8 | 11.0 |
| SEER | 14.0 | 14.0 | 14.0 |
| CFM | 1200 | 1450 | 1275/1850 |
| System power (KW) | 3.08 | 3.98 | 5.04 |
| Refrigerant type | R410A | R410A | R410A |
| Refrigerant charge (lb-oz) | | | |
| System 1 | 13-8 | 13-10 | 11-10 |
| ARI HEATING PERFORMANCE | | | |
| 47°F capacity rating (MBH) | 36,000 | 44,000 | 51,500 |
| System power (KW) / COP | 3.15 (kW) / 3.35 | 4.03 (kW) / 3.20 | 4.5 (kW) / 3.35 |
| 17°F capacity rating (MBH) | 19,000 | 24,900 | 30,000 |
| System power (KW) / COP | 2.5 (kW) / 2.2 | 3.48 (kW) / 2.10 | 4.11 (kW) / 2.14 |
| HSPF (Btu/Watts-hr) | 8.00 | 8.00 | 8.00 |
| DIMENSIONS (inches) | | | |
| Length | 82-1/4 | 82-1/4 | 82-1/4 |
| Width | 44-7/8 | 44-7/8 | 44-7/8 |
| Height | 32-5/8 | 32-5/8 | 32-5/8 |
| OPERATING WT. (lbs.) | 610 | 616 | 620 |
| COMPRESSORS | | | |
| Type | Scroll | Scroll | Scroll ¹ |
| Quantity | 1 | 1 | 1 |
| CONDENSER COIL DATA | | | |
| Face area (Sq. Ft.) | 16.88 | 16.88 | 16.88 |
| Rows | 2 | 2 | 2 |
| Fins per inch | 18 | 18 | 18 |
| Tube diameter | 3/8 | 3/8 | 3/8 |
| Circuitry Type | Split-face | Split-face | Split-face |
| Refrigerant control | TXV | TXV | TXV |
| EVAPORATOR COIL DATA | | | |
| Face area (Sq. Ft.) | 5.06 | 5.06 | 5.06 |
| Rows | 4 | 4 | 4 |
| Fins per inch | 13 | 13 | 13 |
| Tube diameter | 0.375 | 0.375 | 0.375 |
| Circuitry Type | Split-face | Split-face | Split-face |
| Refrigerant control | TXV | TXV | TXV |

Table 8: XN036-060 Physical Data (Continued)

| Component | Models | | | | | |
|---|-------------|-------|------------------|-------|--------------------|----------------|
| | XN036 | | XN048 | | XN060 | |
| Nominal Tonnage | 3.0 | | 4.0 | | 5.0 | |
| CONDENSER FAN DATA | | | | | | |
| Quantity | 1 | | 1 | | 1 | |
| Fan diameter (Inch) | 24 | | 24 | | 24 | |
| Type | Prop | | Prop | | Prop | |
| Drive type | Direct | | Direct | | Direct | |
| No. speeds | 1 | | 1 | | 2 | |
| Number of motors | 1 | | 1 | | 1 | |
| Motor HP each | 1/4 | | 1/4 ² | | 1/2 ² | |
| RPM | 850 | | 850 | | 850/1100 | |
| CFM | 3000 | | 3300 | | 2800/3800 | |
| BELT DRIVE EVAP FAN DATA | | | | | | |
| Quantity | 1 | | 1 | | 1 | |
| Fan diameter (Inch) | 11 x 10 | | 11 x 10 | | 11 x 10 | |
| Type | Centrifugal | | Centrifugal | | Centrifugal | |
| Motor Sheave | 1VL44 | 1VP56 | 1VL44 | 1VP56 | 1VL44 | 1VP56 |
| Blower Sheave | AK64 | AK66 | AK56 | AK61 | AK56 | AK56 |
| Belt | A37 | A39 | A36 | A38 | A36 | A38 |
| Motor HP each | 1-1/2 | 1-1/2 | 1-1/2 | 1-1/2 | 1-1/2 ³ | 2 ³ |
| RPM | 1740 | | 1740 | | 1740 | |
| Frame size | 56 | | 56 | | 56 | |
| DIRECT DRIVE EVAP FAN DATA⁴ | | | | | | |
| Quantity | 1 | | 1 | | 1 | |
| Fan Size (Inch) | 11 x 10 | | 11 x 10 | | 11 x 10 | |
| Type | Centrifugal | | Centrifugal | | Centrifugal | |
| Motor HP each | 3/4 | | 1 | | 1 | |
| RPM | 1050 | | 1050 | | 1050 | |
| FILTERS | | | | | | |
| 15" x 20" x 1" or 2" | 2 | | 2 | | 2 | |
| 14" x 25" x 1" or 2" | 1 | | 1 | | 1 | |

1. 2-Speed Scroll Compressor
2. ECM O. D. Fan Motor
3. I. D. Fan Motor with VFD
4. Only available On 208/230 Volt Models

Optional Electric Heat

The factory or field installed heaters are wired for single point power supply. Power supply need only be brought into the single point terminal block, and thermostat wiring to the low voltage terminal strip located in the upper portion of the unit control box.

These CSA approved heaters are located within the central compartment of the unit with the heater elements extending in to the supply air chamber.

Fuses are supplied, where required, by the factory. Some kW sizes require fuses and others do not. refer to Table 9 for minimum CFM limitations and to Table 7 for electrical data.

Table 9: Electric Heat Minimum Supply Air

| Size (Tons) | Voltage | Minimum Supply Air (CFM) | | | | | |
|--------------|--------------|--------------------------|------|------|------|------|------|
| | | Heater kW | | | | | |
| | | 5 | 7 | 10 | 15 | 20 | 30 |
| 036 (3.0) | 208/230-1-60 | 900 | 900 | 900 | 900 | 900 | - |
| | 208/230-3-60 | 900 | 900 | 900 | 900 | 900 | - |
| | 460-3-60 | - | 900 | 900 | 900 | 900 | - |
| | 600-3-60 | - | - | 900 | 900 | 900 | - |
| 048 (4.0) | 208/230-1-60 | 1200 | 1200 | 1200 | 1200 | 1200 | - |
| | 208/230-3-60 | 1200 | 1200 | 1200 | 1200 | 1200 | - |
| | 460-3-60 | - | 1200 | 1200 | 1200 | 1200 | - |
| | 600-3-60 | - | - | 1200 | 1200 | 1200 | - |
| 060 (5.0) | 208/230-1-60 | 1500 | 1500 | 1500 | 1500 | 1500 | 1500 |
| | 208/230-3-60 | 1500 | 1500 | 1500 | 1500 | 1500 | 1500 |
| | 460-3-60 | - | 1500 | 1500 | 1500 | 1500 | 1500 |
| | 600-3-60 | - | - | 1500 | 1500 | 1500 | 1500 |

Options/Accessories

Economizer/Motorized Damper and Rain Hood

The instruction for the optional economizer/motorized damper rain hood can be found in form 5004998. Use these instructions when field assembling an economizer rain hood onto a unit. The outdoor and return air dampers, the damper actuator, the damper linkage, the outdoor and return air divider baffles, and all the control sensors are factory mounted as part of the "Factory installed" economizer/motorized damper options.

Power Exhaust/barometric Relief Damper and Rain Hood

The instructions for the power exhaust/barometric relief damper and rain hood can be found in form 1200060.

All of the components, including the dampers, hardware, and mounting instructions are shipped in a single package external from the unit and must be field assembled and installed.

Power exhaust is only available as a field installed accessory.

Economizer And Power Exhaust Set Point Adjustments

Remove the top rear access panel from the unit. Locate the economizer control module, where the following adjustments will be made.



Extreme care must be exercised in turning all set point, maximum and minimum damper positioning adjustment screws to prevent twisting them off.

Minimum Position Adjustment

- Check that the damper blades move smoothly without binding; carefully turn the Minimum Position Adjust screw (found on the damper control module) fully clockwise and then set the thermostat indoor fan switch to the ON position and then OFF or energize and de-energize terminals "R" to "G".
- With the thermostat set to the indoor fan ON position or terminals "R" to "G" energized, turn the Minimum Position Adjusting screw (located on the damper control module) counterclockwise until the desired minimum damper position has been attained.

Economizer Sequences

Several functions can drive the economizer, including: minimum position, free cooling, economizer loading, and minimum outdoor air supply.

Economizer Minimum Position

The economizer minimum position is set during occupied mode when outside air is not suitable for free cooling. The position of the damper is set proportionally between the "Economizer Minimum Position and the Economizer Minimum Position Low Speed Fan" set points, in relationship to the VFD output percentage. On a constant volume single speed supply fan system both set-points should be set to the same value.

Free Cooling

Four types of free cooling options are available: dry bulb changeover, single enthalpy, dual enthalpy changeover, and Auto.

Dry Bulb Changeover

For dry bulb economizer operation, the outside air is suitable for free cooling if the outside air temperature is 1°F below the Economizer OAT Enable Setpoint **and** 1°F below the Return Air Temperature.

Free cooling is no longer available if the outside air temperature rises above **either** the Economizer OAT Enable setpoint **or** the return air temperature.

Single Enthalpy Changeover

For single enthalpy economizer operation, the outside air is suitable for free cooling if the outside air enthalpy is at least 1 BTU/lb below the Economizer Outside Air Enthalpy Setpoint **and** the outside air temperature is no greater than the RAT plus 9°F.

If the outside air temperature rises above the RAT plus 10°F, free cooling is no longer available. The outside air temperature must drop to no greater than RAT plus 9°F to enter free cooling again.

Free cooling is no longer available if the outside air enthalpy rises above the Economizer Outside Air Enthalpy Setpoint.

Dual Enthalpy Changeover

For dual enthalpy economizer operation, the outside air enthalpy must be lower than the return air enthalpy by 1 btu/lb **AND** the outside air temperature is no greater than the RAT plus 9°F.

Auto

The control determines the type of free cooling changeover based on which sensors are present and reliable. Conditions include:

- Return and outside air dry bulb = dry bulb changeover
- Return and outside air dry bulb and outside air humidity = single enthalpy
- Return and outside air dry bulb and return and outside air humidity = dual enthalpy
- If either the return or outside air dry bulb sensors are unreliable, free cooling is not available

Free Cooling Operation

When the control determines that the outside air is suitable, the first stage of cooling will always be free cooling.

Thermostat

In free cooling, with a thermostat input to Y1, the dampers modulate to control the supply air temperature to the Economizer Setpoint +/- 1°F (default 55°F).

If the thermostat provides an input to Y2 **and** the parameter Compressors Off in Free Cooling is turned OFF a compressor output energizes. The economizer dampers continue to

modulate to control the supply air temperature to the Economizer Setpoint.

If the supply air temperature cannot be maintained within 5°F of the economizer setpoint, the first stage compressor (C1) will be turned on. Second stage compressor (C2) will be added as needed to keep the supply air temperature within the 5°F of the economizer setpoint.

Sensor

In free cooling, with a demand from the zone/return sensor for the first stage of cooling, the dampers modulate to control the supply air temperature to the Economizer Setpoint +/- 1°F.

If the economizer output is at 100% **and** the SAT is greater than the Economizer setpoint + 1°F, the control starts a 12-minute timer to energize a compressor output.

If at any time the economizer output drops below 100% the timer stops and resets when the economizer output returns to 100%.

Once a compressor output is turned ON, the economizer dampers continue to modulate to control the supply air temperature to the Economizer Setpoint.

At no time will a compressor output be turned ON if the economizer output is less than 100%, even if the differential between zone (or return) temperature and the current cooling setpoint is great enough to demand more than one stage of cooling.

If the economizer output goes to minimum position **and** the SAT is less than Economizer Setpoint -1°F, the control starts a 12-minute timer to de-energize a compressor output.

If at any time the economizer output goes above the minimum position the timer stops and resets when the economizer output returns to minimum position.

If the demand for cooling from the space/return is satisfied, the economizer output will modulate to minimum position and the compressor outputs will be de-energized as long as their minimum run timers have expired.

Power Exhaust

Setpoints

| | |
|--------------------------------------|-------------|
| a. Economizer Enable | ON |
| b. Power Exhaust Enable | ON |
| c. Modulating Power Exhaust | OFF |
| d. Exhaust VFD Installed | OFF |
| e. Building Pressure Sensor Enabled | OFF |
| f. Econo Damper Position For Exh Fan | ON Percent |
| g. Econo Damper Position For Exh Fan | OFF Percent |

Inputs

No inputs are present for non-modulating power exhaust.

Outputs

- a. 2-10 VDC from ECON on Economizer Expansion module
- b. 24 VAC from EX-FAN to energize exhaust fan on Economizer Expansion module

- a. Compares economizer output to the Economizer Damper Position For Exhaust Fan On and OFF.
- b. Energizes exhaust fan when economizer output is above Economizer Damper Position For Exhaust Fan On.
- c. De-energizes exhaust fan when economizer output is below the Economizer Damper Position for Exhaust Fan OFF

Operation

Operation details include:

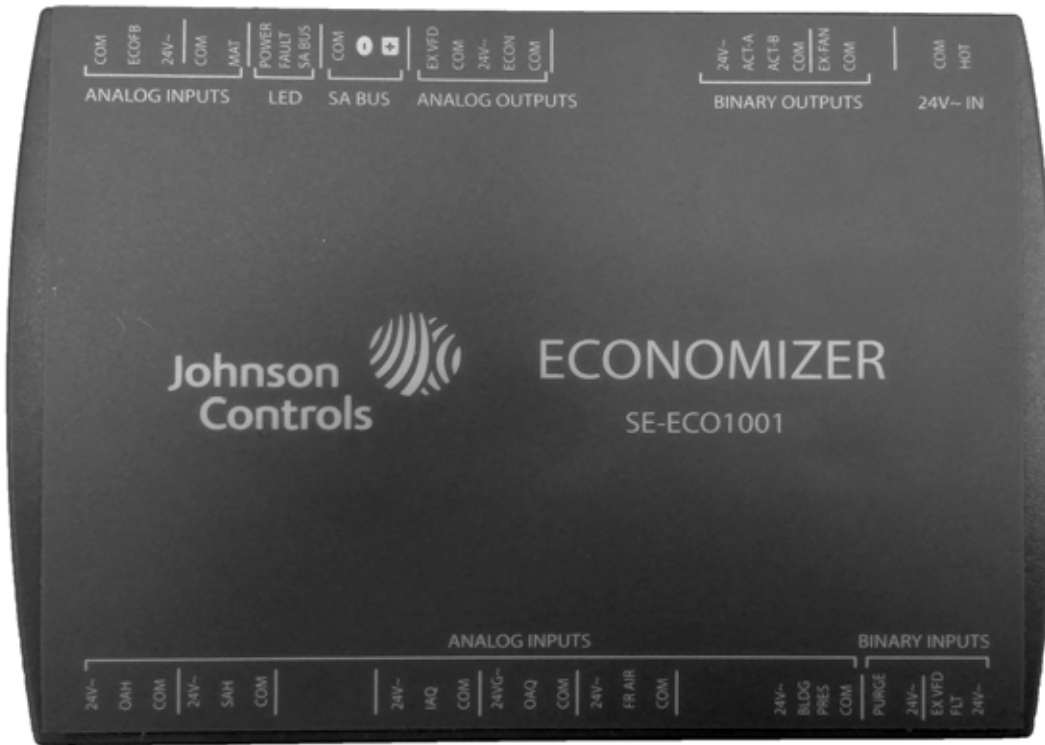

Figure 13: SE-ECO1001-0 Economizer Controller

Table 10: Simplicity SE Economizer Board Details

| Board Label | Cover Label | Description | Function & Comments |
|--|-------------|---|---|
| Directional orientation: viewed with the center text of the cover label upright | | | |
| ANALOG INPUTS Terminal at left on upper edge of economizer board | | | |
| C | COM | 24 VAC common/0-10 VDC negative for economizer actuator position feedback | Connects through circuit trace to 24V~ IN pin COM |
| IN2 | ECOFB | 0-10 VDC positive input from Economizer actuator position Feedback | EconDampPos parameter reports input status (0-100%). Used to meet Cali. Title 24 requirements for economizer actuator position feedback |
| R | 24V~ | 24 VAC hot supplied for economizer actuator position feedback | Connects through circuit trace to 24V~ IN pin HOT |
| C | COM | Mixed Air Temperature sensor input from 10KΩ @ 77°F, Type III negative temperature coefficient thermistor | MAT parameter reports input status (°F/°C), 3.65 VDC reading MAT (+) to COM (-) with open circuit. Read-only use in current control revision. |
| IN1 | MAT | | |
| LEDs at left on upper edge of economizer board | | | |
| POWER | POWER | Green UCB power indicator | Lit indicates 24 VAC is present at 24V~ IN COM and HOT pins |
| FAULT | FAULT | Red networking error and firmware error indicator | 1/10th second on/off flashing indicates a networking error (polarity, addressing, etc.) or a firmware error (likely correctable with re-loading from USB flash drive) |

Table 10: Simplicity SE Economizer Board Details (Continued)

| Board Label | Cover Label | Description | Function & Comments |
|---|-------------|--|--|
| SA BUS | SA BUS | Green UCB SA bus communication transmission indicator | Lit/flickering indicates UCB-to-economizer board SA bus communication is currently active, off indicates the economizer board is awaiting SA bus communication |
| SA BUS Pin connections at left on upper edge of economizer board | | | |
| C | COM | Common for SA BUS power and communication circuits | EconCtrlr parameter reports UCB-to-economizer board SA bus communication status. Negative of the SA BUS communication circuit to the UCB. Through the unit wiring harness, may continue on to the 4-stage board and/or fault detection & diagnostics board |
| - | - | Communication for SA BUS devices | EconCtrlr parameter reports UCB-to-economizer board SA BUS communication status. Positive of the VDC (typically, a fluctuating 1.5 to 3.5 volts reading to C; at least 0.25 volts lower than +) SA BUS communication circuit to the UCB. Through the unit wiring harness, may continue on to the 4-stage board and/or fault detection & diagnostics board |
| + | + | Communication for SA BUS devices | EconCtrlr parameter reports UCB-to-economizer board SA BUS communication status. Positive of the VDC (typically, a fluctuating 1.5 to 3.5 volts reading to C; at least 0.25 volts higher than -) SA BUS communication circuit to the UCB. Through the unit wiring harness, may continue on to the 4-stage board and/or fault detection & diagnostics board |
| ANALOG OUTPUTS Pin at center on upper edge of economizer board | | | |
| J4 | EX VFD | 2-10 VDC positive output for the modulating power Exhaust fan Variable Frequency Drive/ discharge damper modulating power exhaust actuator | ExFanVFD parameter reports output status (0-100%) when ExFType selection is Variable Frequency Fan; EAD-O parameter reports output status (0-100%) when ExFType selection is Modulating Damper. Used to ramp the power exhaust fan VFD/ position the discharge damper actuator. |
| | COM | 24 VAC common/0-10 VDC negative for the power exhaust variable frequency drive/ discharge damper modulating power exhaust actuator | Connects through circuit trace to 24V~ IN pin COM |
| | 24V~ | 24 VAC hot supplied for the discharge damper modulating power exhaust actuator and economizer actuator | Connects through circuit trace to 24V~ IN pin HOT |
| | ECON | 2-10 VDC output for the Economizer actuator | Econ parameter reports output status (0-100%). Used to position the economizer actuator for minimum position, free cooling, demand ventilation, cooling economizer loading and purge functions |
| | COM | 24 VAC common/0-10 VDC negative for economizer actuator | Connects through circuit trace to 24V~ IN pin COM |

Table 10: Simplicity SE Economizer Board Details (Continued)

| Board Label | Cover Label | Description | Function & Comments |
|---|-------------|--|---|
| BINARY OUTPUTS Pin at right on upper edge of economizer board | | | |
| J3 | 24V~ | 24 VAC hot supplied for an incremental (floating control) economizer actuator | Connects through circuit trace to 24V~ IN pin HOT |
| | ACT-A | 24 VAC hot outputs to position an incremental (floating control) economizer actuator | Unused in current control revision |
| | ACT-B | 24 VAC return | Unused in current control revision |
| | COM | 24 VAC common for an incremental (floating control) economizer actuator | Connects through circuit trace to 24V~ IN pin COM |
| | EX-FAN | 24 VAC hot output to energize power exhaust fan contactor coil/VFD enable relay coil | ExFan parameter reports output status (Off-On) when ExFType selection is Non-Modulating, Modulating Damper or Variable Frequency Fan. Used to turn on/enable the power exhaust fan motor. |
| | COM | 24 VAC common/0-10 VDC negative for economizer actuator | Connects through circuit trace to 24V~ IN pin COM |
| 24V~ IN Pin connections at right on upper edge of economizer board | | | |
| C | COM | 24 VAC transformer Common referenced to cabinet ground | 24 VAC common connection to power the economizer board. Connects through circuit traces to C/COM terminals and pins distributed on the economizer board. |
| R | HOT | 24 VAC transformer HOT | 24 VAC hot connection to power the economizer board. Connects through circuit traces to R/24V~ terminals and pins distributed on the economizer board. |
| ANALOG INPUTS Terminal on lower edge of economizer board | | | |
| R | 24V~ | 24 VAC hot supplied for the outdoor air humidity sensor | Connects through circuit trace to 24V~ IN pin HOT |
| IN3 | OAH | 0-10 VDC positive input from the Outdoor Air Humidity sensor | OAH parameter reports input status (0-100%H). Used in outdoor air enthalpy calculation for dual enthalpy economizer free cooling changeover. |
| C | COM | 24 VAC common/0-10 VDC negative for the outdoor air humidity sensor | Connects through circuit trace to 24V~ IN pin COM |
| R | 24V~ | 24 VAC hot supplied for the supply air humidity sensor | Connects through circuit trace to 24V~ IN pin HOT |
| IN4 | SAH | 0-10 VDC positive input from the Supply Air Humidity sensor | SAH parameter reports input status (0-100%H). Unused in current control revision. |
| C | COM | 24 VAC common/0-10 VDC negative for the supply air humidity sensor | Connects through circuit trace to 24V~ IN pin COM |
| R | 24V~ | 24 VAC hot supplied for the indoor air quality sensor | Connects through circuit trace to 24V~ IN pin HOT |
| IN5 | IAQ | 0-10 VDC positive input from the Indoor Air Quality sensor | IAQRange parameter sets the CO2 parts per million measured by the indoor air quality sensor when it outputs 10 VDC; IAQ parameter reports input status (0-5000ppm). Used for demand ventilation functions if the NetIAQ parameter indicates ?Unrel. |
| C | COM | 24 VAC common/0-10 VDC negative for the indoor air quality sensor | Connects through circuit trace to 24V~ IN pin COM |
| R | 24V~ | 24 VAC hot supplied for the outdoor air quality sensor | Connects through circuit trace to 24V~ IN pin HOT |

Table 10: Simplicity SE Economizer Board Details (Continued)

| Board Label | Cover Label | Description | Function & Comments |
|---|-------------|--|--|
| IN6 | OAQ | 0-10 VDC positive input from the Outdoor Air Quality sensor | OAQRange parameter sets the CO2 parts per million measured by the outdoor air quality sensor when it outputs 10 VDC; OAQ parameter reports input status (0-5000ppm). Used for demand ventilation function when DVent-Mode selection is Diff between IAQ and OAQ and the NetOAQ parameter indicates ?Unrel. |
| C | COM | 24 VAC common/0-10 VDC negative for the outdoor air quality sensor | Connects through circuit trace to 24V~ IN pin COM |
| R | 24V~ | 24 VAC hot supplied for the air monitoring station sensor | Connects through circuit trace to 24V~ IN pin HOT |
| IN7 | FR AIR | 0-10 VDC positive input from the air monitoring station sensor | MOA-Range parameter sets the cubic feet per minute/liters per second measured by the air monitoring station sensor when it outputs 10 VDC; Fr Air parameter reports input status (0-50000CFM/23595lps). Used for economizer minimum position reset in speed-controlled indoor blower applications. |
| C | COM | 24 VAC common/0-10 VDC negative for the air monitoring station sensor | Connects through circuit trace to 24V~ IN pin COM |
| R | 24V~ | 24 VAC hot supplied for the building pressure sensor | Connects through circuit trace to 24V~ IN pin HOT |
| IN8 | BLDG PRES | 0-5 VDC positive input from the Building Pressure sensor | BldgPres parameter reports input status (-.250-.250"/w/-.062-.062kPa). Used for modulating power exhaust functions when ExFType selection is Modulating Damper or Variable Frequency Fan. |
| C | COM | 24 VAC common/0-5 VDC negative for the building pressure sensor | Connects through circuit trace to 24V~ IN pin COM |
| BINARY INPUTS at right on lower edge of economizer board | | | |
| IN9 | PURGE | 24 VAC hot input from the PURGE dry contact | Purge parameter reports input status (False with 0 VAC input-True with 24 VAC input). When Purge status is True, heating and cooling operation is prevented, the indoor blower and power exhaust fan operate, the economizer actuator is positioned to 100%. |
| | 24V~ | 24 VAC hot supplied for the purge dry contact | Connects through circuit trace to 24V~ IN pin HOT |
| IN10 | EX VFD FLT | 24 VAC hot input from the power Exhaust Variable Frequency Drive Fault contact | ExFanVFDFIt parameter reports input status (Normal with 0 VAC input-Alarm with 24 VAC input) when ExFType selection is Variable Frequency Fan. When ExFanVFDFIt status is Alarm, EX-FAN fan output is prevented. |
| | 24V~ | 24 VAC hot supplied for the power exhaust variable frequency drive fault contact | Connects through circuit trace to 24V~ IN pin HOT |

Indoor Air Quality - IAQ

Indoor Air Quality (indoor sensor input): The Indoor Air Quality sensor is connected to the economizer board through the IAQ analog input terminal and the associated COM and 24V~ inputs on the economizer board. Terminal IAQ accepts a 0 to +10 Vdc signal with respect to the (IAQ) terminal. When the signal is below its set point, the actuator is allowed to modulate normally in accordance with the enthalpy and mixed air sensor inputs. When the IAQ signal exceeds its set point setting, and there is no call for free cooling, the actuator is proportionately modulated from the 0 to 10 Vdc signal, with 0 Vdc corresponding to full closed and 10 Vdc corresponding to full open. When there is no call for free cooling, the damper position is limited by the IAQ Max damper position setting.

When the signal exceeds its set point (Demand Control Ventilation Set Point) setting and there is a call for free cooling, the actuator modulates from the minimum position to the full open position based on the highest call from either the mixed air sensor input or the IAQ voltage input.

- Optional CO2 Space Sensor Kit Part #2AQ04700524
- Optional CO2 Sensor Kit Part #2AQ04700624

Phasing

XN units are properly phased at the factory. Check for proper compressor rotation. If the blower or compressors rotate in the wrong direction at start-up, the electrical connection to the unit is misphased. Change the phasing of the **Field Line**

Connection at the factory or field supplied disconnect to obtain proper rotation. (Scroll compressors operate in only one direction. If the scroll is drawing low amperage, has similar suction and discharge pressures, or producing a high noise level, the scroll is misphased.)

CAUTION

Scroll compressors require proper rotation to operate correctly. Units are properly phased at the factory. Do not change the internal wiring to make the blower condenser fans, or compressor rotate correctly.

CAUTION

When installing equipment in a facility with a 3 phase high-leg delta power supply, care must be taken to ensure that the high-leg conductor is not attached to either of the two legs of the (single phase, direct drive) X13 or ECM motors. Failure to do so can result in the motor acting erratically or not running at all.

Check for the high leg conductor by checking voltage of each phase to ground.

Example: A or L1 phase to ground, voltage reading is 120V. B or L2 phase to ground, voltage reading is 195 to 208V. C or L3 phase to ground, voltage reading is 120V. Therefore B or L2 phase is the high Leg. The high should always be wired to the center or B or L2 tap.

Note: Check all three phase motors and compressors for proper rotation after making a change. If it is necessary to change 3 phase motor rotation, swap A or L1 and C or L3 only.

Blower Rotation

Check for proper supply air blower rotation. If the blower is rotating backwards, the line voltage at the unit point of power connection is misphased (See 'PHASING').

Belt Tension

The tension on the belt should be adjusted as shown in Figure 14.

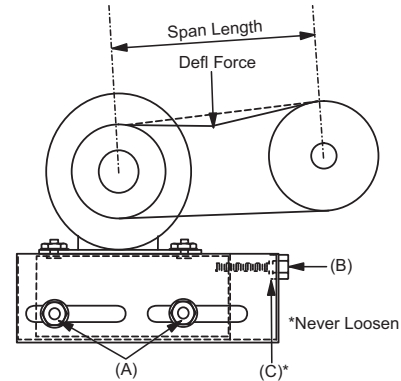

Figure 14: Belt Adjustment

CAUTION

Procedure for adjusting belt tension:

1. Loosen six nuts (top and bottom) A.
2. Adjust by turning (B).
3. Never loosen nuts (C).
4. Use belt tension checker to apply a perpendicular force to one belt at the midpoint of the span as shown. Deflection distance of 4mm (5/32") is obtained. To determine the deflection distance from normal position, use a straight edge from sheave to sheave as reference line. The recommended deflection force is as follows: Tension new belts at the max. deflection force recommended for the belt section. Check the belt tension at least two times during the first 24 hours of operation. Any retensioning should fall between the min. and max. deflection force values.
5. After adjusting re-tighten nuts (A).

CFM Static Pressure and Power-Altitude and Temperature Corrections

The information below should be used to assist in application of product when being applied at altitudes at or exceeding 1000 feet above sea level.

The air flow rates listed in the standard blower performance tables are based on standard air at sea level. As the altitude or temperature increases, the density of air decreases. In order to use the indoor blower tables for high altitude applications, certain corrections are necessary.

A centrifugal fan is a "constant volume" device. This means that, if the rpm remains constant, the CFM delivered is the same regardless of the density of the air. However, since the air at high altitude is less dense, less static pressure will be generated and less power will be required than a similar application at sea level. Air density correction factors are shown in Table 11 and Figure 15.

Table 11: Altitude/Temperature Correction Factors

| Air Temp. | Altitude (Ft.) | | | | | | | | | | |
|-----------|----------------|-------|-------|-------|-------|-------|-------|-------|-------|-------|-------|
| | 0 | 1000 | 2000 | 3000 | 4000 | 5000 | 6000 | 7000 | 8000 | 9000 | 10000 |
| 40 | 1.060 | 1.022 | 0.986 | 0.950 | 0.916 | 0.882 | 0.849 | 0.818 | 0.788 | 0.758 | 0.729 |
| 50 | 1.039 | 1.002 | 0.966 | 0.931 | 0.898 | 0.864 | 0.832 | 0.802 | 0.772 | 0.743 | 0.715 |
| 60 | 1.019 | 0.982 | 0.948 | 0.913 | 0.880 | 0.848 | 0.816 | 0.787 | 0.757 | 0.729 | 0.701 |
| 70 | 1.000 | 0.964 | 0.930 | 0.896 | 0.864 | 0.832 | 0.801 | 0.772 | 0.743 | 0.715 | 0.688 |
| 80 | 0.982 | 0.947 | 0.913 | 0.880 | 0.848 | 0.817 | 0.787 | 0.758 | 0.730 | 0.702 | 0.676 |
| 90 | 0.964 | 0.929 | 0.897 | 0.864 | 0.833 | 0.802 | 0.772 | 0.744 | 0.716 | 0.689 | 0.663 |
| 100 | 0.946 | 0.912 | 0.880 | 0.848 | 0.817 | 0.787 | 0.758 | 0.730 | 0.703 | 0.676 | 0.651 |

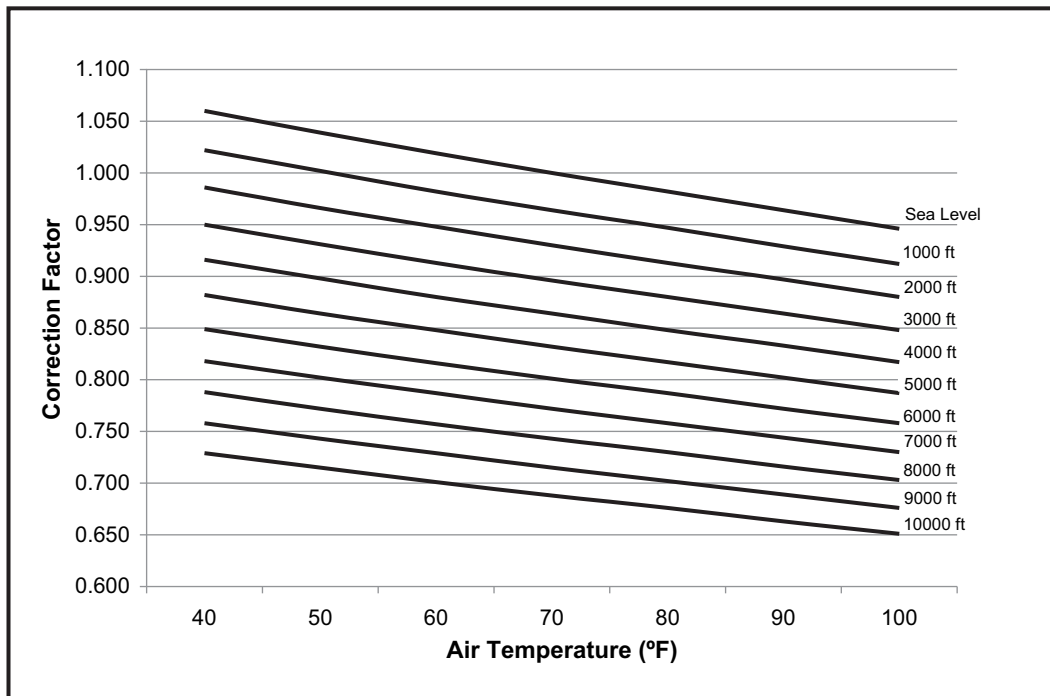
**Figure 15: Altitude/Temperature Correction Factors**

The examples below will assist in determining the airflow performance of the product at altitude.

Example 1: What are the corrected CFM, static pressure, and BHP at an elevation of 5,000 ft. if the blower performance data is 1,400 CFM, 0.6 IWC and 0.67 BHP?

Solution: At an elevation of 5,000 ft. the indoor blower will still deliver 1,400 CFM if the rpm is unchanged. However, Table 12 must be used to determine the static pressure and BHP. Since no temperature data is given, we will assume an air temperature of 70°F. Table 11 shows the correction factor to be 0.832.

$$\text{Corrected static pressure} = 0.6 \times 0.832 = 0.499 \text{ IWC}$$

$$\text{Corrected BHP} = 0.67 \times 0.832 = 0.56$$

Example 2: A system, located at 5,000 feet of elevation, is to deliver 1,400 CFM at a static pressure of 1.5". Use the unit

blower tables to select the blower speed and the BHP requirement.

Solution: As in the example above, no temperature information is given so 70°F is assumed.

The 1.5" static pressure given is at an elevation of 5,000 ft. The first step is to convert this static pressure to equivalent sea level conditions.

$$\text{Sea level static pressure} = 0.6 / .832 = 0.72"$$

Enter the blower table at 1,400 sCFM and static pressure of 0.72". The rpm listed will be the same rpm needed at 5,000 ft.

Suppose that the corresponding BHP listed in the table is 0.7. This value must be corrected for elevation.

$$\text{BHP at 5,000 ft.} = 0.7 \times .832 = 0.58$$

Drive Selection

1. Determine side or bottom supply air duct application.
2. Determine desired airflow.
3. Calculate or measure the amount of external static pressure.
4. Using the operating point determined from steps 1, 2 & 3, locate this point on the appropriate supply air blower performance table. (Linear interpolation may be necessary.)
5. Noting the RPM and BHP from step 4, locate the appropriate motor and/or drive on the RPM selection table.
6. Review the BHP compared to the motor options available. Select the appropriate motor and/or drive.
7. Review the RPM range for the motor options available. Select the appropriate drive if multiple drives are available for the chosen motor.
8. Determine turns open to obtain the desired operation point.

Example

1. 2200 CFM
2. 1.6 iwg
3. Using the supply air blower performance table below, the following data point was located: 1478 RPM & 1.82 BHP.
4. Using the RPM selection table below, Size X and Model Y is found.
5. 1.82 BHP exceeds the maximum continuous BHP rating of the 1.5 HP motor. The 2 HP motor is required.
6. 1478 RPM is within the range of the 2 HP drive.
7. Using the 2 HP motor and drive, 2.5 turns open will achieve 1478 RPM.

Example Supply Air Blower Performance

| Air Flow (CFM) | Available External Static Pressure - IWG | | | | | | | | | | | | | | | | | | | |
|----------------|--|------|-----------------------|------|------|------|------|------|--------------------------|------|------|------|------|------|------|------|------|------|------|------|
| | 0.2 | | 0.4 | | 0.6 | | 0.8 | | 1.0 | | 1.2 | | 1.4 | | 1.6 | | 1.8 | | 2.0 | |
| | RPM | BHP | RPM | BHP | RPM | BHP | RPM | BHP | RPM | BHP | RPM | BHP | RPM | BHP | RPM | BHP | RPM | BHP | RPM | BHP |
| | Field Supplied Drive | | Standard Drive Option | | | | | | High Static Drive Option | | | | | | | | | | | |
| 2000 | 907 | 1.00 | 990 | 1.07 | 1070 | 1.15 | 1146 | 1.23 | 1220 | 1.31 | 1291 | 1.40 | 1359 | 1.49 | 1425 | 1.58 | 1488 | 1.68 | 1550 | 1.77 |
| 2200 | 960 | 1.24 | 1043 | 1.31 | 1123 | 1.39 | 1199 | 1.47 | 1273 | 1.55 | 1344 | 1.64 | 1412 | 1.73 | 1478 | 1.82 | 1541 | 1.92 | 1602 | 2.01 |
| 2400 | 1015 | 1.51 | 1099 | 1.59 | 1178 | 1.66 | 1255 | 1.74 | 1329 | 1.83 | 1400 | 1.92 | 1468 | 2.01 | 1534 | 2.10 | 1597 | 2.19 | 1658 | 2.29 |
| 2600 | 1074 | 1.83 | 1157 | 1.90 | 1237 | 1.98 | 1314 | 2.06 | 1387 | 2.14 | 1458 | 2.23 | - | - | - | - | - | - | - | - |

Table X: RPM Selection

| Size (Tons) | Model | HP | Max BHP | Motor Sheave | Blower Sheave | 5 Turns Open | 4 Turns Open | 3 Turns Open | 2 Turns Open | 1 Turn Open | Fully Closed |
|-------------|-------|-----|---------|--------------|---------------|--------------|--------------|--------------|--------------|-------------|--------------|
| X | Y | 1.5 | 1.73 | 1VL44 | AK56 | 930 | 995 | 1060 | 1130 | 1195 | 1260 |
| | | 2 | 2.3 | 1VP56 | AK56 | 1325 | 1395 | 1460 | 1525 | 1590 | 1660 |

Table 12: XN Blower Performance Side Duct

XN036 (3 Ton Belt Drive) Side Duct

| Air Flow (CFM) | Available External Static Pressure - IWG ¹ | | | | | | | | | | | | | | | | | | | |
|-------------------|---|------|-----|------|-----------------------|------|------|------|--------------------------|------|------|------|------|------|------|------|------|------|------|------|
| | 0.2 | | 0.4 | | 0.6 | | 0.8 | | 1 | | 1.2 | | 1.4 | | 1.6 | | 1.8 | | 2 | |
| | RPM | BHP | RPM | BHP | RPM | BHP | RPM | BHP | RPM | BHP | RPM | BHP | RPM | BHP | RPM | BHP | RPM | BHP | RPM | BHP |
| | Field Supplied Drive | | | | Standard Drive Option | | | | High Static Drive Option | | | | | | | | | | | |
| 800 | 678 | 0.31 | 761 | 0.39 | 840 | 0.47 | 917 | 0.56 | 991 | 0.65 | 1062 | 0.74 | 1130 | 0.84 | 1195 | 0.94 | 1259 | 1.04 | 1320 | 1.16 |
| 1000 | 699 | 0.37 | 782 | 0.44 | 862 | 0.51 | 939 | 0.60 | 1012 | 0.69 | 1083 | 0.79 | 1151 | 0.88 | 1217 | 0.99 | 1280 | 1.10 | 1341 | 1.20 |
| 1200 | 727 | 0.40 | 810 | 0.47 | 889 | 0.56 | 966 | 0.64 | 1040 | 0.73 | 1110 | 0.82 | 1179 | 0.93 | 1244 | 1.02 | 1308 | 1.13 | 1369 | 1.23 |
| 1400 | 759 | 0.46 | 842 | 0.53 | 922 | 0.61 | 998 | 0.69 | 1072 | 0.79 | 1143 | 0.88 | 1211 | 0.98 | 1276 | 1.08 | 1340 | 1.19 | 1401 | 1.30 |
| 1600 | 795 | 0.56 | 878 | 0.63 | 958 | 0.70 | 1035 | 0.79 | 1108 | 0.88 | 1179 | 0.98 | 1247 | 1.07 | 1313 | 1.18 | 1376 | 1.28 | 1438 | 1.39 |
| | | | | | | | | | | | | | | | | | | | | FS4 |

1. Blower performance includes 1" filters. See STATIC RESISTANCE table for additional applications.
2. See RPM SELECTION table to determine desired motor sheave setting and to determine the maximum continuous BHP.
3. kW = BHP x 0.932.
4. Field Supplied Drive.

XN048 (4 Ton Belt Drive) Side Duct

| Air Flow (CFM) | Available External Static Pressure - IWG ¹ | | | | | | | | | | | | | | | | | | | |
|-------------------|---|------|-----|------|-----------------------|------|------|------|------------|------|------|------|------|------|------|------|------|------|------|------|
| | 0.2 | | 0.4 | | 0.6 | | 0.8 | | 1 | | 1.2 | | 1.4 | | 1.6 | | 1.8 | | 2 | |
| | RPM | BHP | RPM | BHP | RPM | BHP | RPM | BHP | RPM | BHP | RPM | BHP | RPM | BHP | RPM | BHP | RPM | BHP | RPM | BHP |
| | Field Supplied Drive | | | | Standard Drive Option | | | | High Drive | | | | | | | | | | | |
| 1000 | 699 | 0.37 | 782 | 0.44 | 862 | 0.51 | 939 | 0.60 | 1012 | 0.69 | 1083 | 0.79 | 1151 | 0.88 | 1217 | 0.99 | 1280 | 1.10 | 1341 | 1.20 |
| 1200 | 727 | 0.40 | 810 | 0.47 | 889 | 0.56 | 966 | 0.64 | 1040 | 0.73 | 1110 | 0.82 | 1179 | 0.93 | 1244 | 1.02 | 1308 | 1.13 | 1369 | 1.23 |
| 1400 | 759 | 0.46 | 842 | 0.53 | 922 | 0.61 | 998 | 0.69 | 1072 | 0.79 | 1143 | 0.88 | 1211 | 0.98 | 1276 | 1.08 | 1340 | 1.19 | 1401 | 1.30 |
| 1600 | 795 | 0.56 | 878 | 0.63 | 958 | 0.70 | 1035 | 0.79 | 1108 | 0.88 | 1179 | 0.98 | 1247 | 1.07 | 1313 | 1.18 | 1376 | 1.28 | 1438 | 1.39 |
| 1800 | 836 | 0.68 | 919 | 0.76 | 999 | 0.84 | 1075 | 0.93 | 1149 | 1.01 | 1220 | 1.11 | 1288 | 1.21 | 1353 | 1.31 | 1417 | 1.41 | 1478 | 1.52 |
| 2000 | 880 | 0.86 | 963 | 0.94 | 1042 | 1.02 | 1119 | 1.11 | 1193 | 1.19 | 1263 | 1.29 | 1331 | 1.39 | 1397 | 1.49 | 1460 | 1.59 | 1522 | 1.70 |

1. Blower performance includes 1" filters. See STATIC RESISTANCE table for additional applications.
2. See RPM SELECTION table to determine desired motor sheave setting and to determine the maximum continuous BHP.
3. kW = BHP x 0.932.
4. Field Supplied Drive.

XN060 (5 Ton Belt Drive) Side Duct

| Air Flow (CFM) | Available External Static Pressure - IWG ¹ | | | | | | | | | | | | | | | | | | | |
|-------------------|---|------|------|------|-----------------------|------|------|------|-------------------|------|------|------|------|------|------|------|------|------|------|------|
| | 0.2 | | 0.4 | | 0.6 | | 0.8 | | 1 | | 1.2 | | 1.4 | | 1.6 | | 1.8 | | 2 | |
| | RPM | BHP | RPM | BHP | RPM | BHP | RPM | BHP | RPM | BHP | RPM | BHP | RPM | BHP | RPM | BHP | RPM | BHP | RPM | BHP |
| | Field Supplied Drive | | | | Standard Drive Option | | | | High Static Drive | | | | | | | | | | | |
| 1200 | 727 | 0.40 | 810 | 0.47 | 889 | 0.56 | 966 | 0.64 | 1040 | 0.73 | 1110 | 0.82 | 1179 | 0.93 | 1244 | 1.02 | 1308 | 1.13 | 1369 | 1.23 |
| 1400 | 759 | 0.46 | 842 | 0.53 | 922 | 0.61 | 998 | 0.69 | 1072 | 0.79 | 1143 | 0.88 | 1211 | 0.98 | 1276 | 1.08 | 1340 | 1.19 | 1401 | 1.30 |
| 1600 | 795 | 0.56 | 878 | 0.63 | 958 | 0.70 | 1035 | 0.79 | 1108 | 0.88 | 1179 | 0.98 | 1247 | 1.07 | 1313 | 1.18 | 1376 | 1.28 | 1438 | 1.39 |
| 1800 | 836 | 0.68 | 919 | 0.76 | 999 | 0.84 | 1075 | 0.93 | 1149 | 1.01 | 1220 | 1.11 | 1288 | 1.21 | 1353 | 1.31 | 1417 | 1.41 | 1478 | 1.52 |
| 2000 | 880 | 0.86 | 963 | 0.94 | 1042 | 1.02 | 1119 | 1.11 | 1193 | 1.19 | 1263 | 1.29 | 1331 | 1.39 | 1397 | 1.49 | 1460 | 1.59 | 1522 | 1.70 |
| 2200 | 926 | 1.08 | 1009 | 1.16 | 1089 | 1.24 | 1166 | 1.33 | 1239 | 1.41 | 1310 | 1.51 | 1378 | 1.61 | 1444 | 1.71 | 1507 | 1.82 | 1568 | 1.92 |
| 2400 | 976 | 1.35 | 1059 | 1.42 | 1138 | 1.51 | 1215 | 1.59 | 1289 | 1.68 | 1359 | 1.77 | 1428 | 1.88 | 1493 | 1.97 | 1557 | 2.08 | 1618 | 2.19 |
| 2600 | 1028 | 1.66 | 1111 | 1.73 | 1190 | 1.80 | 1267 | 1.90 | 1340 | 1.98 | 1411 | 2.08 | 1479 | 2.18 | 1545 | 2.28 | 1608 | 2.39 | - | - |

1. Blower performance includes 1" filters. See STATIC RESISTANCE table for additional applications.
2. See RPM SELECTION table to determine desired motor sheave setting and to determine the maximum continuous BHP.
3. kW = BHP x 0.932.
4. Field Supplied Drive.

XN036 - 060 (3-5 Ton Direct Drive) Side Duct

| UNIT TONNAGE | MOTOR ¹ SPEED | AVAILABLE EXTERNAL STATIC PRESSURE - IWG ² | | | | | | | | | | | | | | | | | |
|----------------|--------------------------|---|-------|------|-------|------|-------|------|-------|------|-------|------|-------|------|-------|------|-------|------|-------|
| | | 0.2 | | 0.3 | | 0.4 | | 0.5 | | 0.6 | | 0.7 | | 0.8 | | 0.9 | | 1.0 | |
| | | CFM | WATTS | CFM | WATTS | CFM | WATTS | CFM | WATTS | CFM | WATTS | CFM | WATTS | CFM | WATTS | CFM | WATTS | CFM | WATTS |
| 3 ³ | 5 (HI) | 1528 | 320 | 1485 | 335 | 1445 | 349 | 1409 | 363 | 1370 | 376 | 1334 | 390 | 1292 | 403 | 1254 | 417 | 1213 | 430 |
| | 4 (MED/HI) | 1437 | 263 | 1391 | 276 | 1349 | 290 | 1308 | 303 | 1265 | 316 | 1220 | 329 | 1173 | 343 | 1119 | 358 | 1048 | 374 |
| | 3 (MED) | 1293 | 208 | 1248 | 221 | 1205 | 234 | 1160 | 246 | 1113 | 258 | 1065 | 272 | 1001 | 288 | 934 | 303 | 892 | 313 |
| | 2 (MED/LOW) | 1191 | 171 | 1144 | 183 | 1096 | 195 | 1045 | 207 | 991 | 220 | 925 | 235 | 865 | 248 | - | - | - | - |
| | 1 (LOW) | 1044 | 130 | 963 | 134 | 903 | 145 | 833 | 158 | - | - | - | - | - | - | - | - | - | - |
| 4 ³ | 5 (HI) | - | - | 2007 | 696 | 1968 | 714 | 1933 | 734 | 1896 | 749 | 1855 | 764 | 1806 | 769 | 1719 | 743 | 1574 | 685 |
| | 4 (MED/HI) | 1857 | 539 | 1822 | 557 | 1786 | 571 | 1746 | 585 | 1713 | 602 | 1671 | 619 | 1628 | 638 | 1574 | 657 | 1500 | 676 |
| | 3 (MED) | 1672 | 408 | 1633 | 426 | 1586 | 438 | 1550 | 455 | 1509 | 472 | 1462 | 490 | 1408 | 505 | 1363 | 521 | 1330 | 536 |
| | 2 (MED/LOW) | 1475 | 321 | 1435 | 335 | 1388 | 352 | 1359 | 362 | 1319 | 376 | 1271 | 393 | 1220 | 411 | 1186 | 422 | 1142 | 437 |
| | 1 (LOW) | 1293 | 223 | 1252 | 237 | 1196 | 247 | - | - | - | - | - | - | - | - | - | - | - | - |
| 5 ³ | 5 (HI) | 2245 | 883 | 2247 | 931 | 2236 | 950 | 2211 | 964 | 2171 | 979 | 2114 | 971 | 2034 | 940 | 1948 | 898 | 1855 | 854 |
| | 4 (MED/HI) | 2135 | 771 | 2116 | 784 | 2108 | 808 | 2078 | 826 | 2041 | 844 | 2004 | 859 | 1955 | 861 | 1886 | 843 | 1792 | 806 |
| | 3 (MED) | 2010 | 637 | 1989 | 656 | 1975 | 675 | 1938 | 696 | 1900 | 715 | 1867 | 730 | 1822 | 740 | 1784 | 756 | 1716 | 748 |
| | 2 (MED/LOW) | 1857 | 539 | 1822 | 557 | 1786 | 571 | 1746 | 585 | 1713 | 602 | 1671 | 619 | 1628 | 638 | 1574 | 657 | 1500 | 676 |
| | 1 (LOW) | 1293 | 223 | 1252 | 237 | 1196 | 247 | - | - | - | - | - | - | - | - | - | - | - | - |

1. Factory set on medium speed tap.
2. Includes allowances for a wet evaporator coil and 1" filters. Refer to STATIC RESISTANCES Table for resistance values.
3. Side Duct application (230 Volts)

Table 13: XN Blower Performance Bottom Duct

XN036 (3 Ton Belt Drive) Bottom Duct

| Air Flow (CFM) | Available External Static Pressure - IWG ¹ | | | | | | | | | | | | | | | | | | | |
|----------------|---|------|-----|------|-----------------------|------|------|------|-------------------|------|------|------|------|------|------|------|------|------|------|------|
| | 0.2 | | 0.4 | | 0.6 | | 0.8 | | 1 | | 1.2 | | 1.4 | | 1.6 | | 1.8 | | 2 | |
| | RPM | BHP | RPM | BHP | RPM | BHP | RPM | BHP | RPM | BHP | RPM | BHP | RPM | BHP | RPM | BHP | RPM | BHP | RPM | BHP |
| | Field Supplied Drive | | | | Standard Drive Option | | | | High Static Drive | | | | | | | | | | | |
| 800 | 661 | 0.33 | 751 | 0.40 | 838 | 0.48 | 922 | 0.57 | 1002 | 0.65 | 1079 | 0.75 | 1153 | 0.84 | 1225 | 0.94 | 1294 | 1.04 | 1361 | 1.15 |
| 1000 | 685 | 0.38 | 775 | 0.45 | 862 | 0.52 | 945 | 0.61 | 1025 | 0.69 | 1103 | 0.79 | 1177 | 0.88 | 1248 | 0.98 | 1317 | 1.08 | 1384 | 1.19 |
| 1200 | 714 | 0.41 | 805 | 0.48 | 892 | 0.56 | 975 | 0.64 | 1055 | 0.73 | 1132 | 0.82 | 1207 | 0.92 | 1278 | 1.02 | 1347 | 1.12 | 1414 | 1.22 |
| 1400 | 749 | 0.47 | 840 | 0.53 | 927 | 0.62 | 1010 | 0.70 | 1090 | 0.79 | 1167 | 0.88 | 1242 | 0.98 | 1313 | 1.07 | 1382 | 1.18 | 1449 | 1.29 |
| 1600 | 789 | 0.56 | 880 | 0.63 | 967 | 0.70 | 1050 | 0.79 | 1130 | 0.88 | 1207 | 0.97 | 1282 | 1.06 | 1353 | 1.17 | 1422 | 1.26 | 1489 | 1.37 |
| | FS4 | | | | | | | | | | | | | | | | | | | |

1. Blower performance includes 1" filters. See STATIC RESISTANCE table for additional applications.
2. See RPM SELECTION table to determine desired motor sheave setting and to determine the maximum continuous BHP.
3. kW = BHP x 0.932.

XN048 (4 Ton Belt Drive) Bottom Duct

| Air Flow (CFM) | Available External Static Pressure - IWG ¹ | | | | | | | | | | | | | | | | | | | |
|----------------|---|------|-----|------|-----------------------|------|------|------|-------------------|------|------|------|------|------|------|------|------|------|------|------|
| | 0.2 | | 0.4 | | 0.6 | | 0.8 | | 1 | | 1.2 | | 1.4 | | 1.6 | | 1.8 | | 2 | |
| | RPM | BHP | RPM | BHP | RPM | BHP | RPM | BHP | RPM | BHP | RPM | BHP | RPM | BHP | RPM | BHP | RPM | BHP | RPM | BHP |
| | Field Supplied Drive | | | | Standard Drive Option | | | | High Static Drive | | | | | | | | | | | |
| 1200 | 714 | 0.41 | 805 | 0.48 | 892 | 0.56 | 975 | 0.64 | 1055 | 0.73 | 1132 | 0.82 | 1207 | 0.92 | 1278 | 1.02 | 1347 | 1.12 | 1414 | 1.22 |
| 1400 | 749 | 0.47 | 840 | 0.53 | 927 | 0.62 | 1010 | 0.70 | 1090 | 0.79 | 1167 | 0.88 | 1242 | 0.98 | 1313 | 1.07 | 1382 | 1.18 | 1449 | 1.29 |
| 1600 | 789 | 0.56 | 880 | 0.63 | 967 | 0.70 | 1050 | 0.79 | 1130 | 0.88 | 1207 | 0.97 | 1282 | 1.06 | 1353 | 1.17 | 1422 | 1.26 | 1489 | 1.37 |
| 1800 | 833 | 0.69 | 924 | 0.77 | 1011 | 0.84 | 1094 | 0.93 | 1174 | 1.01 | 1251 | 1.11 | 1326 | 1.20 | 1397 | 1.30 | 1466 | 1.40 | 1533 | 1.51 |
| 2000 | 881 | 0.86 | 971 | 0.94 | 1058 | 1.01 | 1142 | 1.10 | 1222 | 1.19 | 1299 | 1.28 | 1373 | 1.37 | 1445 | 1.48 | 1514 | 1.58 | 1580 | 1.68 |
| | FS4 | | | | | | | | | | | | | | | | | | | |

1. Blower performance includes 1" filters. See STATIC RESISTANCE table for additional applications.
2. See RPM SELECTION table to determine desired motor sheave setting and to determine the maximum continuous BHP.
3. kW = BHP x 0.932.

XN060 (5 Ton Belt Drive) Bottom Duct

| Air Flow (CFM) | Available External Static Pressure - IWG ¹ | | | | | | | | | | | | | | | | | | | |
|----------------|---|------|------|------|------|------|-----------------------|------|------|------|------|------|-------------------|------|------|------|------|------|------|------|
| | 0.2 | | 0.4 | | 0.6 | | 0.8 | | 1 | | 1.2 | | 1.4 | | 1.6 | | 1.8 | | 2 | |
| | RPM | BHP | RPM | BHP | RPM | BHP | RPM | BHP | RPM | BHP | RPM | BHP | RPM | BHP | RPM | BHP | RPM | BHP | RPM | BHP |
| | Field Supplied Drive | | | | | | Standard Drive Option | | | | | | High Static Drive | | | | | | | |
| 1200 | 714 | 0.41 | 805 | 0.48 | 892 | 0.56 | 975 | 0.64 | 1055 | 0.73 | 1132 | 0.82 | 1207 | 0.92 | 1278 | 1.02 | 1347 | 1.12 | 1414 | 1.22 |
| 1400 | 749 | 0.47 | 840 | 0.53 | 927 | 0.62 | 1010 | 0.70 | 1090 | 0.79 | 1167 | 0.88 | 1242 | 0.98 | 1313 | 1.07 | 1382 | 1.18 | 1449 | 1.29 |
| 1600 | 789 | 0.56 | 880 | 0.63 | 967 | 0.70 | 1050 | 0.79 | 1130 | 0.88 | 1207 | 0.97 | 1282 | 1.06 | 1353 | 1.17 | 1422 | 1.26 | 1489 | 1.37 |
| 1800 | 833 | 0.69 | 924 | 0.77 | 1011 | 0.84 | 1094 | 0.93 | 1174 | 1.01 | 1251 | 1.11 | 1326 | 1.20 | 1397 | 1.30 | 1466 | 1.40 | 1533 | 1.51 |
| 2000 | 881 | 0.86 | 971 | 0.94 | 1058 | 1.01 | 1142 | 1.10 | 1222 | 1.19 | 1299 | 1.28 | 1373 | 1.37 | 1445 | 1.48 | 1514 | 1.58 | 1580 | 1.68 |
| 2200 | 932 | 1.08 | 1022 | 1.16 | 1109 | 1.23 | 1193 | 1.32 | 1273 | 1.40 | 1350 | 1.50 | 1424 | 1.59 | 1496 | 1.69 | 1565 | 1.79 | 1631 | 1.90 |
| 2400 | 986 | 1.34 | 1076 | 1.41 | 1163 | 1.49 | 1246 | 1.57 | 1327 | 1.66 | 1404 | 1.75 | 1478 | 1.85 | 1550 | 1.95 | 1619 | 2.05 | 1685 | 2.15 |
| 2600 | 1042 | 1.64 | 1132 | 1.71 | 1219 | 1.78 | 1303 | 1.87 | 1383 | 1.95 | 1460 | 2.05 | 1534 | 2.14 | 1606 | 2.25 | 1675 | 2.34 | | FS4- |

1. Blower performance includes 1" filters. See STATIC RESISTANCE table for additional applications.
2. See RPM SELECTION table to determine desired motor sheave setting and to determine the maximum continuous BHP.
3. kW = BHP x 0.932.

XN036 - 060 (3-5 Ton Direct Drive) Bottom Duct

| UNIT TONNAGE | MOTOR ¹ SPEED | AVAILABLE EXTERNAL STATIC PRESSURE - IWG ² | | | | | | | | | | | | | | | | | |
|----------------|--------------------------|---|-------|------|-------|------|-------|------|-------|------|-------|------|-------|------|-------|------|-------|------|-------|
| | | 0.2 | | 0.3 | | 0.4 | | 0.5 | | 0.6 | | 0.7 | | 0.8 | | 0.9 | | 1.0 | |
| | | CFM | WATTS | CFM | WATTS | CFM | WATTS | CFM | WATTS | CFM | WATTS | CFM | WATTS | CFM | WATTS | CFM | WATTS | CFM | WATTS |
| 3 ³ | 5 (HI) | 1476 | 320 | 1435 | 335 | 1396 | 349 | 1361 | 363 | 1324 | 376 | 1289 | 390 | 1249 | 403 | 1212 | 417 | 1172 | 430 |
| | 4 (MED/HI) | 1388 | 263 | 1344 | 276 | 1303 | 290 | 1264 | 303 | 1222 | 316 | 1179 | 329 | 1134 | 343 | 1082 | 358 | 1013 | 374 |
| | 3 (MED) | 1250 | 208 | 1206 | 221 | 1164 | 234 | 1121 | 246 | 1076 | 258 | 1029 | 272 | 968 | 288 | 903 | 303 | 863 | 313 |
| | 2 (MED/LOW) | 1151 | 171 | 1105 | 183 | 1060 | 195 | 1010 | 207 | 958 | 220 | 895 | 235 | - | - | - | - | - | - |
| | 1 (LOW) | 1009 | 130 | 932 | 134 | 874 | 145 | - | - | - | - | - | - | - | - | - | - | - | - |
| 4 ³ | 5 (HI) | 1975 | 636 | 1937 | 696 | 1900 | 714 | 1866 | 734 | 1831 | 749 | 1791 | 764 | 1743 | 769 | 1660 | 743 | 1520 | 685 |
| | 4 (MED/HI) | 1793 | 539 | 1759 | 557 | 1724 | 571 | 1685 | 585 | 1654 | 602 | 1613 | 619 | 1572 | 638 | 1520 | 657 | 1449 | 676 |
| | 3 (MED) | 1614 | 408 | 1577 | 426 | 1532 | 438 | 1497 | 455 | 1458 | 472 | 1412 | 490 | 1360 | 505 | 1317 | 521 | 1285 | 536 |
| | 2 (MED/LOW) | 1450 | 321 | 1384 | 335 | 1338 | 352 | 1311 | 362 | 1274 | 376 | 1226 | 393 | 1177 | 411 | 1144 | 422 | 1098 | 437 |
| | 1 (LOW) | 1250 | 223 | 1210 | 237 | 1156 | 247 | - | - | - | - | - | - | - | - | - | - | - | - |
| 5 ³ | 5 (HI) | 2166 | 883 | 2169 | 931 | 2158 | 950 | 2134 | 964 | 2095 | 979 | 2040 | 971 | 1963 | 940 | 1881 | 898 | 1791 | 854 |
| | 4 (MED/HI) | 2060 | 771 | 2042 | 784 | 2035 | 808 | 2006 | 826 | 1970 | 844 | 1934 | 859 | 1888 | 861 | 1821 | 843 | 1730 | 806 |
| | 3 (MED) | 1940 | 637 | 1920 | 656 | 1907 | 675 | 1870 | 696 | 1834 | 715 | 1802 | 730 | 1759 | 740 | 1722 | 756 | 1657 | 748 |
| | 2 (MED/LOW) | 1830 | 413 | 1759 | 432 | 1724 | 451 | 1685 | 468 | 1654 | 479 | 1613 | 497 | 1572 | 513 | - | - | - | - |
| | 1 (LOW) | 1250 | 327 | 1210 | 339 | - | - | - | - | - | - | - | - | - | - | - | - | - | - |

1. Factory set on medium speed tap.
2. Includes allowances for a wet evaporator coil and 1" filters. Refer to STATIC RESISTANCES Table for resistance values.
3. Bottom Duct application (230 Volts)

Table 14: Belt Drive RPM Selection

| Size (Tons) | Model | HP | Max BHP | Motor Sheave | Blower Sheave | 5 Turns Open | 4 Turns Open | 3 Turns Open | 2 Turns Open | 1 Turn Open | Fully Closed |
|-------------|-------|-----|---------|--------------|---------------|--------------|--------------|--------------|--------------|-------------|--------------|
| 036 (3) | XN | 1.5 | 1.73 | 1VL44 | AK64 | 816 | 877 | 933 | 994 | 1049 | 1110 |
| | | 1.5 | 1.73 | 1VP56 | AK66 | 1131 | 1186 | 1242 | 1298 | 1354 | 1409 |
| 048 (4) | XN | 1.5 | 1.73 | 1VL44 | AK56 | 943 | 1009 | 1075 | 1146 | 1212 | 1278 |
| | | 1.5 | 1.73 | 1VP56 | AK61 | 1227 | 1288 | 1349 | 1409 | 1475 | 1536 |
| 060 (5) | XN | 1.5 | 1.73 | 1VL44 | AK56 | 943 | 1009 | 1075 | 1146 | 1212 | 1278 |
| | | 2 | 2.3 | 1VP56 | AK56 | 1343 | 1414 | 1480 | 1546 | 1612 | 1683 |

* Field Option Sheave.

Table 15: Indoor Blower Specifications (Belt Drive)

| Size (Tons) | Motor | | | | | Motor Sheave | | | Blower Sheave | | | Belt |
|-------------|-------|------|------|------|-------|------------------|------------|-------|------------------|------------|-------|------|
| | HP | RPM | Eff. | SF | Frame | Datum Dia. (in.) | Bore (in.) | Model | Datum Dia. (in.) | Bore (in.) | Model | |
| 036 (3.0) | 1-1/2 | 1725 | 0.8 | 1.15 | 56 | 2.8 - 3.8 | 7/8 | 1VL44 | 6.0 | 1 | AK64 | A37 |
| | 1-1/2 | 1725 | 0.8 | 1.15 | 56 | 4.0 - 5.0 | 7/8 | 1VP56 | 6.2 | 1 | AK66 | A39 |
| 048 (4.0) | 1-1/2 | 1725 | 0.8 | 1.15 | 56 | 2.8 - 3.8 | 7/8 | 1VL44 | 5.2 | 1 | AK56 | A36 |
| | 1-1/2 | 1725 | 0.8 | 1.15 | 56 | 4.0 - 5.0 | 7/8 | 1VP56 | 5.7 | 1 | AK61 | A38 |
| 060 (5.0) | 1-1/2 | 1725 | 0.8 | 1.15 | 56 | 2.8 - 3.8 | 7/8 | 1VL44 | 5.2 | 1 | AK56 | A36 |
| | 2 | 1725 | 0.8 | 1.15 | 56 | 4.0 - 5.0 | 7/8 | 1VP56 | 5.2 | 1 | AK56 | A38 |

Table 16: Power Exhaust Specifications

| Model | Voltage | Motor | | | Motor | | | Fuse Size | CFM @ 0.1 ESP |
|-------------|--------------|-------|-------------------|-----|-------|-----|-----|-----------|---------------|
| | | HP | RPM | QTY | LRA | FLA | MCA | | |
| 2PE04703725 | 208/230-1-60 | 1/2 | 1725 ¹ | 1 | 23.7 | 4.4 | 5.5 | 8 | 1350 |
| 2PE04703746 | 460-1-60 | 1/2 | 1725 ¹ | 1 | 4.1 | 1.7 | 2.1 | 5 | 1350 |
| 2PE04703758 | 575-3-60 | 1/2 | 1725 | 1 | 4.5 | 0.9 | 1.1 | 2 | 1350 |

1. Motors are multi-tapped and factory wired for high speed.

Checking Supply Air CFM

The RPM of the supply air blower will depend on the required CFM, the unit accessories or options and the static resistances of both the supply and the return air duct systems. With this information, the motor speed tap (direct drive) or the motor pulley number of turns open (belt drive) can be determined from the Blower Performance Data Tables.

⚠ CAUTION

Belt drive blower systems MUST be adjusted to the specific static and CFM requirements for the application. The belt drive blowers are NOT set at the factory for any specific static or CFM. Adjustments of the blower speed and belt tension are REQUIRED. Tighten blower pulley and motor sheave set screws after these adjustments. Re-checking set screws after 10-12 hrs. run time is recommended.

Note the following:

1. The supply air CFM must be within the limitations shown in the Unit Physical Data Table 8.
2. Pulleys can be adjusted in half turn increments.
3. The tension on the belt should be adjusted as shown in the Belt Adjustment Figure 14.
4. Tighten blower pulley and motor sheave set screws after any adjustments. Re-check set screws after 10-12 hrs. run time is recommended.

Start the supply air blower motor. Adjust the resistances in both the supply and the return air duct systems to balance the air distribution throughout the conditioned space. The job specifications may require that this balancing be done by someone other than the equipment installer.

To check the supply air CFM after the initial balancing has been completed:

1. Remove the two 5/16" dot plugs from the blower motor and the filter access panels shown in Figure 7.
2. Insert at least 8" of 1/4 inch tubing into each of these holes for sufficient penetration into the air flow on both sides of the indoor coil.

NOTE: The tubes must be inserted and held in a position perpendicular to the air flow so that velocity pressure will not affect the static pressure readings.

3. Using an inclined manometer, determine the pressure drop across a dry evaporator coil. Since the moisture on an evaporator coil may vary greatly, measuring the pressure drop across a wet coil under field conditions would be inaccurate. To assure a dry coil, the compressors should be deactivated while the test is being run.
4. Knowing the pressure drop across a dry coil, the actual CFM through the unit can be determined from the curve in Pressure Drop vs. Supply Air CFM (Figure 16).

⚠ WARNING

Failure to properly adjust the total system air quantity and static pressure can result in extensive system damage.

After readings have been obtained, remove the tubes and reinstall the two 5/16" dot plugs that were removed in Step 1.

NOTE: De-energize the compressors before taking any test measurements to assure a dry indoor coil.

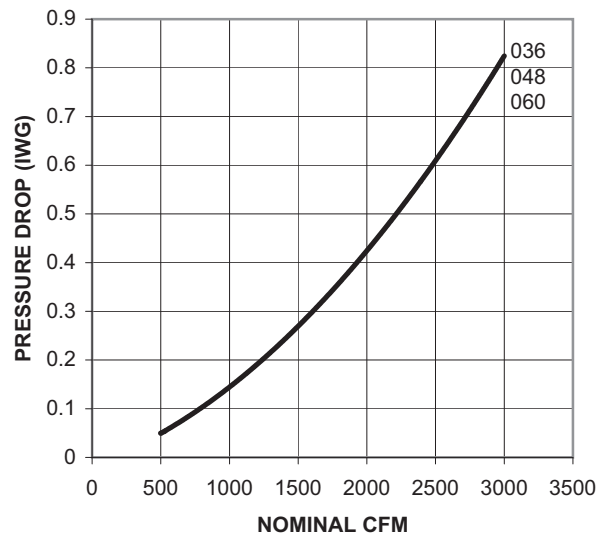

Figure 16: Pressure Drop Across Coil

Table 17: Additional Static Resistance

| Size (Tons) | CFM | Economizer ^{1 2} | Electric Heat kW ¹ | |
|-------------------------------------|------|---------------------------|-------------------------------|---------|
| | | | 7 - 15 | 20 - 30 |
| 036 (3.0) 048 (4.0) 060 (5.0) | 1000 | 0.07 | 0.04 | 0.06 |
| | 1200 | 0.08 | 0.05 | 0.07 |
| | 1400 | 0.09 | 0.06 | 0.08 |
| | 1600 | 0.11 | 0.07 | 0.09 |
| | 1800 | 0.13 | 0.08 | 0.11 |
| | 2000 | 0.15 | 0.10 | 0.13 |
| | 2200 | 0.17 | 0.12 | 0.15 |
| | 2400 | 0.20 | 0.14 | 0.17 |
| | 2600 | 0.23 | 0.16 | 0.20 |
| | 2800 | 0.23 | 0.19 | 0.23 |
| 3000 | 0.30 | 0.22 | 0.26 | |

1. Deduct these values from the available external static pressure shown in the respective Blower Performance Tables.
2. The pressure drop through the economizer is greater for 100% outdoor air than for 100% return air. If the resistance of the return air duct is less than 0.25 IWG, the unit will deliver less CFM during full economizer operation.

Operation

Sequence Of Operation

For the XN series of units, the thermostat makes a circuit between "R" and "Y1" for the first stage of cooling.

The call is passed to the **Unit Control Board (UCB)**, which then determines whether the requested operation is available and, if so, which components to energize.

For heating, the thermostat makes a circuit between "R" and "W1". The UCB energizes the compressor and condenser fan allowing the unit to run in heating mode. A demand defrost control operates the defrost cycle on all 3 thru 5 ton units.

If at any time a call for both heating and cooling are present, the heating operation will be performed. If operating, the cooling system is halted as with a completion of a call for cooling. Heating always takes priority.

Continuous Blower

By setting the room thermostat fan switch to "ON," the supply air blower will operate continuously.

Intermittent Blower

With the room thermostat fan switch set to "AUTO" and the system switch set to either the "AUTO" or "HEAT" settings, the blower is energized whenever a cooling or heating operation is requested. The blower is energized after any specified delay associated with the operation.

When energized, the indoor blower has a minimum run time of 30 seconds. Additionally, the indoor blower has a minimum off delay of 10 seconds.

No Outdoor Air Options

When the thermostat calls for cooling, the low-voltage control circuit from "R" to "Y1" and "G" is completed. The compressor and

condenser fan motor are energized. After completing the specified fan on delay for cooling, the UCB will energize the blower motor.

Once the thermostat has been satisfied, it will de-energize Y1. If the compressor has satisfied its minimum run time, the compressor and condenser fan de-energize. Otherwise, the unit operates the cooling system until the minimum run time for the compressor has been completed. After the compressor de-energizes, the blower is stopped following the elapse of the fan off delay for cooling.

To be available, a compressor must not be locked-out due to a high or low-pressure switch or Evaporator Low Limit sensor (**EC1**) detecting a temperature below 26° F and the anti-short cycle delay (ASCD) must have elapsed.

Economizer With Single Enthalpy Sensor

When the room thermostat calls for cooling, the low voltage control circuit from "R" to "G" and "Y1" is completed. The UCB energizes the blower motor (if the fan switch on the room thermostat is set in the "AUTO" position) and drives the economizer dampers from fully closed to their minimum position. If the enthalpy of the outdoor air is below the setpoint of the enthalpy controller (previously determined), "Y1" energizes the economizer. The dampers will modulate to maintain a constant supply air temperature as monitored by the discharge air sensor. If the outdoor air enthalpy is above the setpoint, "Y1" energizes the compressor and condenser fan motor only.

Once the thermostat has been satisfied, it will de-energize "Y1". If the compressor has satisfied its minimum run time, the compressor and condenser fan are de-energized. Otherwise, the unit operates the cooling system until the minimum run times for the compressor has been completed. After the compressor de-energizes, the blower is stopped following the elapse of the fan off delay for cooling, and the economizer damper goes to the closed position. If the unit is in continuous fan operation the economizer damper goes to the min. position.

Economizer With Dual Enthalpy Sensors

The operation with the dual enthalpy sensors is identical to the single sensor except that a second enthalpy sensor is mounted in the return air. This return air sensor allows the economizer to choose between outdoor air and return air, whichever has the lowest enthalpy value, to provide maximum operating efficiency.

Economizer With Power Exhaust

A unit equipped with an economizer (single or dual enthalpy) and a power exhaust operates as specified above with one addition. The power exhaust motor is energized 45 seconds after the actuator position exceeds the exhaust fan set point on the economizer control. When the power exhaust is operating, the second stage of mechanical cooling will not operate. As always, the "R" to "G" connection provides minimum position but does not provide power exhaust operation.

Motorized Outdoor Air Dampers

This system operation is the same as the units with no outdoor air options with one exception. When the "R" to "G" circuit is complete, the motorized damper drives open to a position set by the thumbwheel on the damper motor. When the "R" to "G" circuit is opened, the damper spring returns fully closed.

Cooling Operation Errors

Each cooling system is monitored for operation outside of the intended parameters. Errors are handled as described below. All system errors override minimum run times for compressors.

High-Pressure Limit Switch

During cooling operation, if a high-pressure limit switch opens, the UCB will de-energize the compressor, initiate the ASCD (Anti-short cycle delay), and stop the condenser fan. If the call for cooling is still present at the conclusion of the ASCD, the UCB will re-energize the compressor.

Should a high-pressure switch open three times within two hours of operation, the UCB will lock-out the associated compressor and sends an error message.

Low-Pressure Limit Switch

The low-pressure limit switch is not monitored during the initial 30 seconds of a cooling system's operation. For the following 30 seconds, the UCB will monitor the low-pressure switch to ensure it closes. If the low-pressure switch fails to close after the 30-second monitoring phase, the UCB will de-energize the compressor, initiate the ASCD, and stop the condenser fan.

Once the low-pressure switch has been proven (closed during the 30-second monitor period described above), the UCB will monitor the low-pressure limit switch for any openings. If the low-pressure switch opens for greater than 5 seconds, the UCB will de-energize the compressor, initiate the ASCD, and stop the condenser fan.

If the call for cooling is still present at the conclusion of the ASCD, the UCB will re-energize the compressor.

Should a low-pressure switch open three times within one hour of operation, the UCB will lock-out the compressor and sends an error message.

Evaporator Low Limit

During cooling operation, if the **Evaporator Low Limit Sensor (EC1)** (Located on the Suction Line at the Evaporator Coil.) detects a temperature below 26 Deg. F (default), the UCB will de-energize the compressor, initiate the ASCD, and stop the condenser fan. If the call for cooling is still present at the conclusion of the ASCD, the UCB will re-energize the halted compressor.

Should the evaporator low limit sensor (**EC1**) detect a temperature below 26°F three times within two hours of operation, the UCB will lock-out the associated compressor and flash an error message.

Low Ambient Cooling

To determine when to operate in low ambient mode, the UCB has an **Outdoor Air Temperature Sensor (OAT)** with a low ambient setpoint at 45°F (default). When the **OAT Sensor** senses a temperature below the low ambient setpoint and the thermostat is calling for cooling, the UCB will operate in the low ambient mode.

Low ambient mode operates the compressors in this manner:

10 minutes on, 5 minutes off. The indoor blower is operated throughout the cycle. The 5-minute off period is necessary to defrost the indoor coil.

Low ambient mode always begins with compressor operation. Compressor minimum run time may extend the minutes of compressor operation. The off cycle will begin immediately following the elapse of the minimum run time.

When operating in low ambient mode, an **Evaporator Low Limit Sensor (EC1)** temperature below 26°F will de-energize the compressor. If the call for cooling is still present at the end of the ASCD and the evaporator temperature (**EC1**) is above 26°F, the unit will resume operation.

Safety Controls

The unit control board monitors the following inputs for each cooling system:

1. An evaporator low limit sensor (**EC1**) (Located on the Suction Line at the Evaporator Coil.) to protect against low evaporator temperatures due to a low airflow or a low return air temperature, set at 26°F.
2. A high-pressure switch to protect against excessive discharge pressures due to a blocked condenser coil or a condenser motor failure, (opens at 625 ± 25 psig).
3. A low-pressure switch to protect against loss of refrigerant charge, (opens at 22 ± 5 psig).

The above pressure switches are hard-soldered to the unit. The refrigeration systems are independently monitored and

controlled. On any fault, only the associated system will be affected by any safety/preventive action.

The unit control board monitors the temperature limit switch of electric heat units and the temperature limit switch and the gas valve of gas furnace units.

Compressor Protection

In addition to the external pressure switches, the compressor also has inherent (internal) protection. If there is an abnormal temperature rise in a compressor, the protector will open to shut down the compressor. The UCB incorporates features to minimize compressor wear and damage. An **Anti-Short Cycle Delay (ASCD)** is utilized to prevent operation of a compressor too soon after its previous run. Additionally, a minimum run time is imposed any time a compressor is energized.

The ASCD is initiated on unit start-up and on any compressor reset or lock-out.

Error Message

The UCB will initiate a error message associated with errors within the system.

Reset

Remove the call for cooling, by raising thermostat setting higher than the conditioned space temperature. This resets any pressure or evaporator low limit error messages.

Heating Sequence Of Operations

With or Without Electric Heat

When the thermostat calls for the first stage of heating, the low voltage control circuit is completed between "R" and "W1". The 24vac signal is passed through the UCB to the Fan, C1 and CN-Fan output Terminals and withholds a 24vac output to the H1 terminal assuring the reversing valve cannot be energized, except during defrost. If the ASCD timer is satisfied the UCB will energize compressor contactor M1.

If the compressor alone cannot satisfy the heating requirements, a second stage call from the thermostat completes the circuit between "R" and "W2". This 24vac signal is passed through the UCB H2 output terminal to the electric heat section (if available). The total available kW of electric heat will be energized on a call for "W2".

Defrost Initiation

Defrost control implements a temperature differential, demand defrost algorithm. The heat pump is allowed to operate in the heating mode until the combination of outdoor ambient

temperature and outdoor coil temperature indicate that defrosting is necessary. When the coil temperature is maintained below the initiate point for a given ambient temperature, continuously for 4-1/2 minutes, the heat pump is put into a defrost cycle. This 4-1/2 minute timer eliminates unnecessary defrost cycles caused by refrigeration surges such as those that occur at the start of a heating cycle.

For defrost, the UCB will signal the energizing of the reversing valve and de-energizing the systems condenser fan motor(s). The unit's optional electric first-stage heater is also energized via a 24-volt VAC output terminal labeled "H2".

Defrost Termination

The UCB terminates the defrost mode when either of the following two conditions are met;

1. The outdoor coil temperature sensor reaches 50°F, or
2. The maximum allowable defrost run time of 8 minutes.

Interval between Defrosts

A timed inhibit feature prevents the system from responding to a call for defrost less than 40 minutes after the initiation of the previous defrost. After this inhibit time has expired, temperature conditions must call for defrost continuously for 4- 1/2 minutes before another defrost cycle is initiated. A temperature inhibit feature prohibits defrost if the coil temperature is above 40°F. All defrost timing occurs only while the compressor is on.

Forced Defrost

A forced-defrost feature puts the system into a defrost cycle every 6 hours and 4 minutes to recirculate lubricants, unless the coil temperature is above 40°F. All defrost timing occurs only while the compressor is on.

For trouble shooting purposes, the defrost cycle can be manually initiated by selecting "Test Defrost" in the UCB menu.

Safety Controls

The electric heat control circuit includes the following safety controls:

Temperature Limit Switch (TLS)

This control is located inside the heater compartment and is set to open at the temperature indicated in the Electric Heat Limit Setting Table 18. It resets automatically. The limit switch operates when a high temperature condition, caused by inadequate supply air flow occurs, thus shutting down the heater and energizing the blower.

Table 18: Electric Heat Limit Setting

| Voltage | kW | Temperature Limit Switch | Open Temperature °F |
|----------|-------------|--------------------------|---------------------|
| 208-1-60 | 5 | 1 | 140 |
| | 7 | 1,3 | 140 |
| | 10 | 1,2,3 | 140 |
| | 15 | 2,4,6 | 140 |
| | 20 | 1,2,3,4,5 | 140 |
| | | 6 | 150 |
| 30 | 1,2,3,4,5,6 | 150 | |
| 230-3-60 | 5 | 1,2,3 | 140 |
| | 7 | 1,2,3 | 140 |
| | 10 | 1,2,3 | 150 |
| | 15 | 2,4,6 | 140 |
| | 20 | 1,2,3,4,5,6 | 150 |
| | | 1,3,5 | 160 |
| 30 | 2,4,6 | 150 | |
| 460-3-60 | 7 | 2,4,6 | 140 |
| | 10 | 2,4,6 | 140 |
| | 15 | 2,4,6 | 140 |
| | 20 | 3 | 160 |
| | 30 | 3 | 150 |
| 575-3-60 | 10 | 2,4,6 | 140 |
| | 15 | 2,4,6 | 140 |
| | 20 | 5 | 160 |
| | 30 | 5 | 150 |

Error Message

The UCB will initiate a error message associated with errors within the system.

Reset

Remove the call for cooling, by raising thermostat setting higher than the conditioned space temperature. This resets any pressure or evaporator low limit error messages.

Electric Heat Anticipator Setpoints

It is important that the anticipator setpoint be correct. Too high of a setting will result in longer heat cycles and a greater temperature swing in the conditioned space. Reducing the value below the correct setpoint will give shorter "ON" cycles and may result in the lowering of the temperature within the conditioned space. Refer to Table 19 for the required electric heat anticipator setting.

Table 19: Electric Heat Anticipator Setpoints

| Heater Kw | Voltage | Setting, Amps | |
|-----------|----------------------|---------------|------|
| | | TH1 | TH2 |
| 5 | 230-1-60 230-3-60 | 0.024 | 0.35 |
| 7 | | 0.024 | 0.35 |
| 10 | | 0.024 | 0.35 |
| 15 | | 0.024 | 0.35 |
| 20 | | 0.024 | 0.35 |
| 30 | | 0.024 | 0.35 |
| 7 | 460-3-60 | 0.024 | 0.35 |
| 10 | | 0.024 | 0.35 |
| 15 | | 0.024 | 0.35 |
| 20 | | 0.024 | 0.37 |
| 30 | | 0.024 | 0.37 |
| 10 | 575-3-60 | 0.024 | 0.35 |
| 15 | | 0.024 | 0.35 |
| 20 | | 0.024 | 0.37 |
| 30 | | 0.024 | 0.37 |

Start-up (Cooling)**Prestart Check List**

After installation has been completed:

1. Check the electrical supply voltage being supplied. Be sure that it is the same as listed on the unit nameplate.
2. Set the room thermostat to the off position.
3. Turn unit electrical power on.
4. Set the room thermostat fan switch to on.
5. Check indoor blower rotation.
 - If blower rotation is in the wrong direction. Refer to Phasing Section in general information section.
 - Check blower drive belt tension.
6. Check the unit supply air (CFM). See "CHECKING SUPPLY AIR CFM" on page 42.
7. Measure evaporator fan motor's amp draw.
8. Set the room thermostat fan switch to off.
9. Turn unit electrical power off.

Operating Instructions

1. Turn unit electrical power on.
2. Set the room thermostat setting to lower than the room temperature.
3. Compressor will energize after the built-in time delay (five minutes).

Post Start Check List

1. Verify proper system pressures.
2. Measure the temperature drop across the evaporator coil.
3. Measure the system Amperage draw across all legs of 3 phase power wires.

4. Measure the condenser fan amp draw.

Shut Down

1. Set the thermostat to highest temperature setting.
2. Turn off the electrical power to the unit.

Simplicity SE Control Board Navigation Components

The following components are needed to access the control points in the Simplicity® SE control. Installation and operation guides are located on www.upgnet.com under Product Center \ Equipment Catalog \ Commercial Products \ Zoning Systems and Controls.

1. Local LCD on Unit Control Board.

OR

2. Mobile Access Portal (MAP) Gateway (Portable).
 - Source 1 P/N S1-JC-MAP1810-OP
3. MAP Gateway Quick Start Guide P/N 24-10737-16
4. MAP Gateway Instruction P/N 24-10737-8

NOTE: For more in-depth sequence of operation of the Simplicity® SE control please refer to 5127915 on www.upgnet.com under Product Center \ Equipment Catalog \ Commercial Products \ Zoning Systems and Controls.

SIMPLICITY™ SE (SMART EQUIPMENT) FIRMWARE VERSION 3. BASIC UNIT CONTROL BOARD NAVIGATION EXAMPLES:

The following document details the navigation and viewing of the LCD display screen equipped as a standard item on the Simplicity SE control installed within various commercial UPG packaged and split system equipment. The following information provides a step-by-step demonstration on how to

navigate the basic status menu and how to change basic configuration settings. The basic navigation steps outlined in this short demonstration applies to most menus within the Simplicity SE control.



Understanding the Local LCD

After you apply power to your Rooftop Unit (RTU), a start-up countdown begins on the Unit Control Board (UCB) LCD. When the controller is ready, the screen is blank because no faults are present. Use the joystick and the two push buttons below the LCD, to navigate through the menus.

Step 1 - After the start-up countdown is complete the first screen displayed is the "Status & Alarms" screen. When the cursor is on the top "Status" line hit the "ENTER" button. This action steps the LCD display into the status mode. Hit "ENTER" to view the status menu.

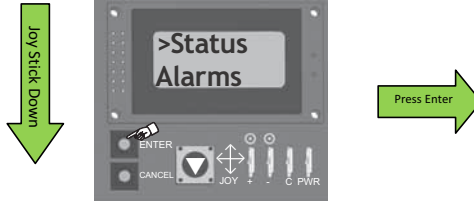

Step 2 - The first item under the status menu is "DVent-Mode". This is the demand ventilation mode.

Step 3 - When the cursor is on the "DVent-Mode" hit "ENTER" to view the status of this mode. In this case a CO2 sensor is not installed, thus Demand Ventilation or DVent is disabled.

Step 4 - To exit out of the "DVent-Mode status screen push "Cancel". The screen returns to that shown below.



Step 5 - By pushing the joystick down, the cursor toggles to OprST (Operating Space Temp).

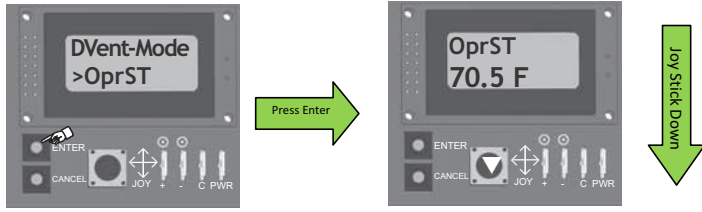

Step 6 - By pushing "ENTER" the actual OprST (Operating Space Temp) appears. Pushing the joystick down scrolls through SAT, RAT, OAT and other available sensor readings.

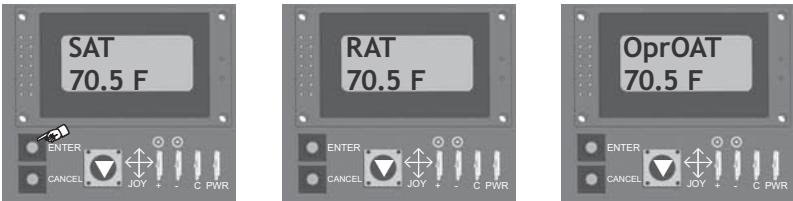

Press the "Cancel" button to exit each menu level. Repeatedly pressing "Cancel" returns the menu to the first "Status, Alarms" screen.

When the "Cancel" button is pressed multiple times to exit each menu level and the screen returns to the first "Status, Alarms" display the next demonstration can begin. In this demonstration the information below steps through the "Commissioning" menu.

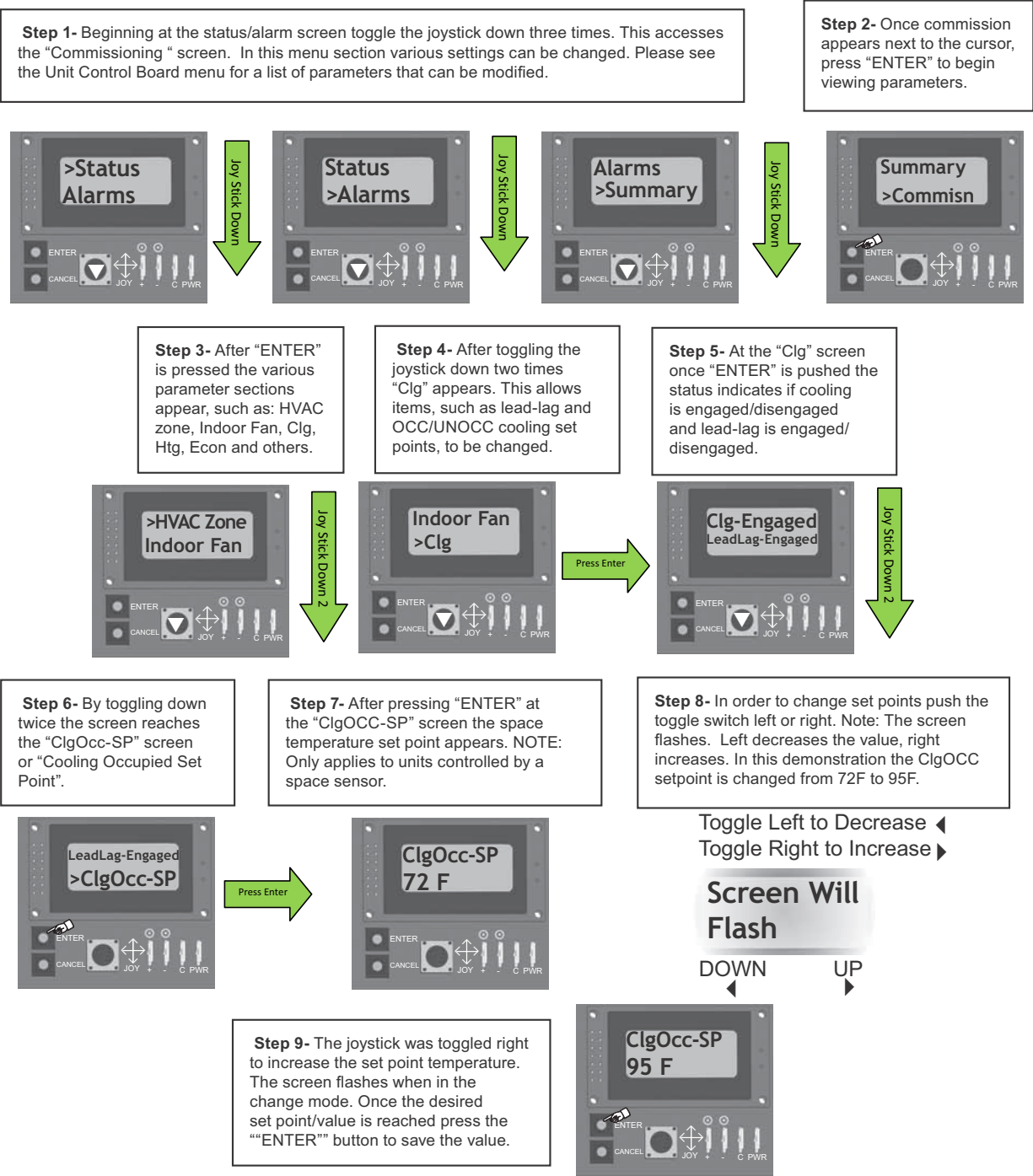

These few pages provide a simple demonstration how to navigate the menu's of the Simplicity SE control containing Version 3 firmware. Please utilize this document along with the additional information in the Users Guide and detailed navigation menu to adjust the control to customer preferences or job specifications.

NOTE: IF OPERATING THE EQUIPMENT WITH A THERMOSTAT, THE UCB SETPOINTS AND PARAMETERS SHOULD NOT REQUIRE ALTERATION; HOWEVER, THERE MAY BE THE CASE WHERE MINIMUM OUTSIDE AIR, LEAD-LAG OR OTHER CUSTOM SETTINGS ARE REQUIRED. PLEASE READ THIS DOCUMENT IN DETAIL TO UNDERSTAND THE IMPLICATIONS OF MAKING CHANGES BEFORE PROCEEDING. IT IS STRONGLY RECOMMENDED THAT A BACKUP OF PARAMETER SETTINGS BE SAVED ON A USB DRIVE BEFORE MAKING ANY MAJOR CHANGES TO THE CONTROL!



Figure 17: Unit Control Board

Table 20: Simplicity SE UCB Details

| Description | | Function & Comments |
|---|--|--|
| Terminal Directional orientation: viewed with silkscreen labels upright | | |
| Limit, 24 VAC power and shutdown connections from unit wiring harness at left on upper edge of UCB | | |
| LIMIT | Monitored 24 VAC input through heat section limit switch(es) | If voltage is absent, indicating the heat section is over-temperature, the UCB will bring on the indoor blower |
| C | 24 VAC, 75 VA transformer Common referenced to cabinet ground | Connects through circuit traces to thermostat connection strip C and indoor blower VFD pin C |
| 24V | 24 VAC, 75 VA transformer hot | Powers the UCB microprocessor, connects through circuit trace to the SD 24 terminal |
| SD 24 | 24 VAC hot out for factory accessory smoke detector, condensate overflow and/or user shutdown relay switching in series | Connects through circuit trace to thermostat connection strip SD-24. A wiring harness jumper plug connecting SD 24 to SD R is in place if factory accessories for unit shutdown are not used - this jumper plug must be removed if the switching of field-added external accessories for unit shutdown are wired between thermostat connection strip SD-24 and R |
| SD R | 24 VAC hot return from factory accessory smoke detector, condensate overflow and user shutdown relay switching in series | Connects through circuit trace to the R terminal on the upper left of the board |
| R | 24 VAC hot for switched inputs to the UCB | Connects through circuit trace to the thermostat connection strip R terminal, right FAN OVR pin, right HPS1 pin, right HPS2 pin, lower DFS pin and lower APS pin |

Table 20: Simplicity SE UCB Details (Continued)

| Description | | Function & Comments |
|---|---|---|
| Terminal Thermostat connection strip on left edge of UCB | | |
| W1 | 1st stage heating request, 24 VAC input switched from R | Not effective for cooling-only units |
| W2 | 2nd stage heating request, 24 VAC input switched from R | Not effective for cooling-only units or units with single-stage heat sections |
| Y1 | 1st stage cooling request, 24 VAC input switched from R | |
| Y2 | 2nd stage cooling request, 24 VAC input switched from R | Visible in the display menu when the #ClgStgs parameter is set for 2 or more, also effective for economizer free cooling supply air temperature reset when the #ClgStgs parameter is set for 1 or more |
| G | Continuous indoor blower request, 24 VAC input switched from R | |
| OCC | Occupancy request, 24 VAC input switched from R | Must have the OccMode parameter set for External to be effective |
| X | Hard lockout indicator, 24 volt output to a light thermostat LED | |
| R | 24 VAC hot for thermostat switching and power | If field-added external accessories for unit shutdown are used, 24 VAC hot return from smoke detector, condensate overflow and/or user shutdown relay switching in series |
| SD-24 | If field-added external accessories for unit shutdown are used, 24 VAC hot out for smoke detector, condensate over- flow and/or user shutdown relay switching in series | Unit wiring harness jumper plug for factory shutdown accessories must be removed if the switching of field-added external accessories for unit shutdown are wired between thermo- stat connection strip SD-24 and R |
| C | 24 VAC common for thermostat power | |
| LEDs on left edge of UCB | | |
| POWER | Green UCB power indicator | Lit indicates 24 VAC is present at C and 24V terminals |
| FAULT | Red hard lockout, networking error and firmware error indicator | 1/2 second on/off flashing indicates one or more alarm is currently active, 1/10th second on/off flashing indicates a networking error (polarity, addressing, etc.) or a firmware error (likely correctable with re-loading from USB flash drive) |
| SA BUS | Green UCB SA bus communication transmission indicator | Lit/flickering indicates UCB SA bus communication is currently active, off indicates the UCB is awaiting SA bus communication |
| Terminal Space temperature sensor connections at center on upper edge of UCB | | |
| ST | Space Temperature sensor input from 10K Ω @ 77°F, Type III negative temperature coefficient thermistor | Positive of VDC circuit (3.625 VDC reading to COM with open circuit), effective if "Thermo- stat-only Control" parameter is set OFF, space sensor override momentarily shorts ST to COM to initiate/terminate temporary occupancy |
| COM | Common for ST and SSO inputs | Negative of VDC circuit for ST and SSO inputs |
| SSO | Space Sensor Offset input from 0 to 20K Ω potentiometer | Positive of VDC circuit (3.625 VDC reading to COM with open circuit), 10K Ω /2.5 VDC is 0°F offset, 0 Ω /0 VDC is maximum above offset and 20K Ω /3.4 VDC is maximum below offset from active space temperature setpoint |
| Pin Temperature sensor connections at right on upper edge of UCB | | |
| SAT+ | Supply Air Temperature sensor input from 10K Ω @ 77°F, Type III negative temperature coefficient thermistor | Input required for operation; 3.625 VDC reading SAT+ to SAT- with open circuit. Used in heat/cool staging cutouts, free cooling operation, demand ventilation operation, comfort ventilation operation, economizer loading operation, VAV cooling operation, hydronic heat operation. |

Table 20: Simplicity SE UCB Details (Continued)

| Description | | Function & Comments |
|--|--|--|
| RAT+ | Return Air Temperature sensor input from 10KΩ @ 77°F, Type III negative temperature coefficient thermistor | Input required for operation; 3.625 VDC reading RAT+ to RAT- with open circuit. Used in return air enthalpy calculation. Substitutes for space temperature if no other space temperature input is present. |
| OAT+ | Outside Air Temperature sensor input from 10KΩ @ 77°F, Type III negative temperature coefficient thermistor | Input required for operation but may be a communicated value; 3.625 VDC reading OAT+ to OAT- with open circuit. Used in heat/cool cutouts, low ambient cooling determination, dry bulb free cooling changeover, outside air enthalpy calculation, economizer loading operation, heat pump demand defrost calculation. |
| CC1+ | #1 refrigerant circuit Condenser Coil temperature sensor input from 10KΩ @ 77°F, Type III negative temperature coefficient thermistor | Input required for heat pump units, not required for A/C units; 3.625 VDC reading CC1+ to CC1- with open circuit. Used in heat pump demand defrost calculation. |
| EC1+ | #1 refrigerant circuit Evaporator Coil temperature sensor input from 10KΩ @ 77°F, Type III negative temperature coefficient thermistor | Input required for operation; 3.625 VDC reading EC1+ to EC1- with open circuit. Used in suction line temperature safety. |
| CC2+ | #2 refrigerant circuit Condenser Coil temperature sensor input from 10KΩ @ 77°F, Type III negative temperature coefficient thermistor | Input required for 2-compressor heat pump units, not required for 2-compressor A/C units, not active for 1-compressor units; 3.625 VDC reading CC2+ to CC2- with open circuit. Used in heat pump demand defrost calculation. |
| EC2+ | #2 refrigerant circuit Evaporator Coil temperature sensor input from 10KΩ @ 77°F, Type III negative temperature coefficient thermistor | Input required for operation of 2-compressor units, not active for 1-compressor units; 3.625 VDC reading EC2+ to EC2- with open circuit. Used in suction line temperature safety. |
| Pinned connections on right edge of UCB | | |
| RAH+ | Return Air Humidity input from 0-10 VDC @ 0-100% RH sensor | Input required for reheat units, optional in all other units, may be a communicated value. Used in return air enthalpy calculation, temperature/humidity setpoint reset, reheat operation. |
| DCT PRS+ | Supply Duct Pressure input from 0-10 VDC @ 0-5" w.c. sensor | Input required for variable air volume units. Used in VAV indoor blower operation. |
| DFS (upper pin) | 24 VAC hot return from Dirty Filter Switch | Optional input; switch closure for greater than 15 seconds during indoor blower operation initiates a notification alarm |
| DFS (lower pin) | 24 VAC hot out for Dirty Filter Switch | Connects through circuit trace to the R terminal |
| APS (upper pin) | 24 VAC hot return from Air Proving Switch | When this optional input is enabled: the air proving switch must close within 30 seconds of initiation of indoor blower operation and not open for greater than 10 seconds during indoor blower operation to allow heat/cool operation and prevent an "APS open" alarm; the air proving switch must open within 30 seconds of termination of indoor blower operation to prevent an "APS stuck closed" notification alarm |
| APS (lower pin) | 24 VAC hot out for Air Proving Switch | Connects through circuit trace to the R terminal |
| C | Common for the VFD output | Negative of the VDC circuit for the VFD output |
| VFD | 2-10 VDC (0-100%) output for the indoor blower Variable Frequency Drive | Output is active with indoor blower operation. For CV units: this output provides stepped IntelliSpeed control of the indoor blower VFD based on fan-only, cooling stage and heating stage outputs. For VAV units: this output provides control of the indoor blower VFD based on supply duct static pressure input and setpoint. |

Table 20: Simplicity SE UCB Details (Continued)

| Description | | Function & Comments |
|--|--|--|
| VFDFLT | 24 VAC hot input from the normally open VFD alarm contact | The VFD alarm contact switches from R within the unit wiring harness. 24 VAC input results in unit shutdown and a "VFD fault" alarm |
| Terminal at lower right corner of UCB | | |
| 24V FOR OUTPUTS | 24 VAC hot for H1, H2, CN-FAN, AUX HGR, FAN C1 and C2 output relay contact switching | Output relay circuitry is isolated from other UCB components and the 24 VAC hot source may be from a second transformer in the unit |
| Pin Heat section connections at right on lower edge of UCB | | |
| H1 | 24 VAC hot output for heat section stage 1 | Not effective for cooling-only units. Output if demand is present and permissions allow one stage or two stages of heat section operation |
| H2 | 24 VAC hot output for heat section stage 2 | Not effective for cooling-only units or units with single-stage heat sections. Output if demand is present and permissions allow two stages of heat section operation |
| MV | 24 VAC hot input confirming heat section operation | Sourced from gas valve in gas heat units or first stage heat contactor in electric heat units. Input within 5 minutes from initiation of H1 output initiates the "Heat On Fan Delay" timer, loss of input following the termination of H1 output initiates the "Heat On Fan Delay" timer, no input within 5 minutes from initiation of H1 output initiates an "Ignition Failure" alarm, input for longer than 5 minutes without H1 output initiates a "Gas Valve Mis-wire" alarm |
| Pin Cooling and fan output connections at right on lower edge of UCB | | |
| CN-FAN | 24 VAC hot output for the condenser fan contactor coil | Output with either C1 or C2 output; interrupted during defrost cycle for heat pump units |
| AUX HGR | 24 VAC hot output for hot gas reheat components | Effective only for reheat units, output with reheat operation |
| FAN | 24 VAC hot output for indoor blower contactor coil/indoor blower VFD enable relay coil | Output with heat/cool operation, G input or schedule demand |
| C1 | 24 VAC hot output for compressor 1 | If demand is present and permissions allow compressor 1 operation; output with compressor cooling, comfort ventilation cooling, reheat or heat pump heating demands |
| C2 | 24 VAC hot output for compressor 2 | Not effective for one stage compressor UCBs. If demand is present and permissions allow compressor 2 operation; output with compressor cooling, comfort ventilation cooling or heat pump heating demands |
| Pin Refrigerant circuit safety switch and indoor blower overload connections at center on lower edge of UCB | | |
| HPS1 (right pin) | 24 VAC hot out for refrigerant circuit 1 High Pressure Switch | Connects through circuit trace to the R terminal |
| HPS1 (left pin) | 24 VAC hot return from refrigerant circuit 1 High Pressure Switch | Input is only considered if C1 output is needed; input must be present to allow C1 output. Three HPS1 trips in a two hour period cause a "High Pressure Switch 1 Lockout" and C1 output is then prevented until alarm reset. Connects through circuit trace to the right LPS1 pin. |
| LPS1 (right pin) | 24 VAC hot out for refrigerant circuit 1 Low Pressure Switch | Connects through circuit trace to the left HSP1 pin |
| LPS1 (left pin) | 24 VAC hot return from refrigerant circuit 1 Low Pressure Switch | Input is only considered after 30 seconds of C1 output; afterwards, input must be present to allow C1 output. Three LPS1 trips in a one hour period cause a "Low Pressure Switch 1 Lockout" and C1 output is then prevented until alarm reset. |
| HPS2 (right pin) | 24 VAC hot out for refrigerant circuit 2 High Pressure Switch | Not effective for one stage compressor UCBs. Connects through circuit trace to the R terminal |

Table 20: Simplicity SE UCB Details (Continued)

| Description | | Function & Comments |
|---|--|---|
| HPS2 (left pin) | 24 VAC hot return from refrigerant circuit 2 High Pressure Switch | Not effective for one stage compressor UCBs. Input is only considered if C2 output is needed; input must be present to allow C1 output. Three HPS2 trips in a two hour period cause a "High Pressure Switch 1 Lockout" and C2 output is then prevented until alarm reset. Connects through circuit trace to the right LPS2 pin. |
| LPS2 (right pin) | 24 VAC hot out for refrigerant circuit 2 Low Pressure Switch | Not effective for one stage compressor UCBs. Connects through circuit trace to the left HSP2 pin |
| LPS2 (left pin) | 24 VAC hot return from refrigerant circuit 2 Low Pressure Switch | Not effective for one stage compressor UCBs. Input is only considered after 30 seconds of C2 output; afterwards, input must be present to allow C2 output. Three LPS2 trips in a one hour period cause a "Low Pressure Switch 2 Lockout" and C2 output is then prevented until alarm reset. |
| FAN OVR (right pin) | 24 VAC hot out for indoor blower FAN Overload relay contact/motor protector switch | Connects through circuit trace to the R terminal |
| FAN OVR (left pin) | 24 VAC hot return from indoor blower FAN Overload relay contact/motor protector switch | Input is only considered if FAN output is needed; input must be present to allow FAN output and unit operation. One FAN OVR trip lasting longer than 5 minutes or three FAN OVR trips in a two hour period cause a "Fan Overload Lockout" and unit operation is then prevented until alarm reset. |
| Terminal SA BUS connections on at left on lower edge and center of UCB | | |
| PWR | Power for SA ("Sensor-Actuator") BUS devices | Also incorporated in the J8 6-pin phone jack connector at the left-center of the board. Positive of the 15 VDC (reading to C) circuit for powering an optional netstat and/or Multi Touch gateway |
| C | Common for SA BUS power and communication circuits | Also incorporated in the J8 6-pin phone jack connector at the left-center of the board. Negative of the SA BUS circuits |
| - | Communication for SA BUS devices | Also incorporated in the J8 6-pin phone jack connector at the left-center of the board. Positive of the VDC (typically, a fluctuating 1.5 to 3.5 volts reading to C; at least 0.25 volts lower than +) SA BUS communication circuit to optional economizer board, 4-stage board, fault detection & diagnostics board, netstat and/or Multi Touch gateway |
| + | Communication for SA BUS devices | Also incorporated in the J8 6-pin phone jack connector at the left-center of the board. Positive of the VDC (typically, a fluctuating 1.5 to 3.5 volts reading to C; at least 0.25 volts higher than -) SA BUS communication circuit to optional economizer board, 4-stage board, fault detection & diagnostics board, netstat and/or Multi Touch gateway |
| J8 | 6-pin phone jack connector | Incorporates the SA BUS terminals for convenience/alternate connection of SA BUS devices, primarily used for temporary service connection of the Multi Touch gateway |
| Item Integrated user interface at lower left corner of UCB | | |
| Display | On-board, 2-line x 8-character back-lit display | On-board display, buttons and joystick allow access to UCB, economizer, 4-stage and FDD board parameters |
| ENTER | Button for display menu acknowledgment and navigation | |
| CANCEL | Button for display menu navigation and zeroing of active compressor ASCD timer | |
| JOY | 4-way Joystick for display menu navigation | |
| Item USB connector at right of UCB | | |
| J10 | Type A female Universal Serial Bus connector | Used for backup, restoration, & copying of board parameters as well as board software updating through a flash drive |

Table 20: Simplicity SE UCB Details (Continued)

| Description | | Function & Comments |
|--|--|--|
| J15 | Factory wired SA Bus connector | |
| Optional communication sub-board at center of UCB | | |
| Terminal FC BUS connections on left edge of the communication board | | |
| FC+ | FC ("Field Connected") BUS BACnet MSTP communication | Positive of the VDC (typically, a fluctuating 1.5 to 3.5 volts reading to COM; at least 0.25 volts higher than -) FC bus BACnet MSTP communication circuit |
| FC- | FC ("Field Connected") BUS BACnet MSTP communication | Positive of the VDC (typically, a fluctuating 1.5 to 3.5 volts reading to COM; at least 0.25 volts lower than +) FC bus BACnet MSTP communication circuit |
| COM | Common for the FC ("Field Connected") BUS BACnet MSTP communication circuit | Negative of the VDC FC bus BACnet MSTP communication circuit |
| SHLD | Shield for the FC ("Field Connected") BUS BACnet MSTP communication circuit | Earth ground reference of the cable to prevent interference on the FC bus BACnet MSTP communication circuit |
| Item Selector in red housing at left on top edge of the communication board | | |
| EOL switch | End Of Line selector switch for the FC BUS BACnet MSTP communication circuit | ON selected only for the UCB that is the terminus of the FC bus BACnet MSTP communication cable to prevent signal "bounce-back" |
| LEDs on the communication board | | |
| EOL | Green End Of Line indicator | Lit indicates the EOL switch is selected ON |
| FC BUS | Green FC bus communication transmission indicator | Lit/flickering indicates outgoing UCB FC bus communication is currently active, off indicates the UCB is awaiting incoming FC bus communication |
| ISO PWR | Green communication board Isolated Power indicator | Lit indicates the UCB is supplying power to the communication sub-board |

Maintenance

Normal Maintenance

CAUTION

Prior to any of the following maintenance procedures, shut off all electric power to the unit to prevent personal injury.

Filters

Inspect once a month. Replace disposable or clean permanent type as necessary. DO NOT replace permanent type with disposable. The dimensional size of the replacement filter must be the same as the replaced filter.

Motors

Outdoor fan motors are permanently lubricated and require no maintenance.

Indoor Blower Motor and Drive - The indoor blower motor features ball bearings that do not require periodic lubrication.

WARNING

Perform all maintenance operations on the blower motor with electric power disconnected from the unit.

On an annual basis, check the motor for accumulations of dust, etc. that may block the cooling slots in the motor shell. Check for loose, damaged or misaligned drive components. Check that all mounting bolts are tight. Replace defective parts as required.

Outdoor Coil

Dirt should not be allowed to accumulate on the outdoor coil surface or other parts in the air circuit. Cleaning should be as often as necessary to keep coil clean. Use a brush, vacuum cleaner attachment, or other suitable means. If water is used to clean coil, be sure electric power to the unit is shut off prior to cleaning.

NOTE: Exercise care when cleaning the coil so that the coil fins are not damaged.

Start-Up Sheet

START-UP & SERVICE DATA INSTRUCTION

COMMERCIAL PACKAGE UNITS

3.0 To 40.0 TONS

START-UP CHECKLIST

Date: _____

Job Name: _____

Customer Name: _____

Address: _____

City: _____ State: _____ Zip: _____

Model Number: _____ Serial Number: _____

Qualified Start-up Technician: _____ Signature: _____

HVAC Contractor: _____ Phone: _____

Address: _____

Contractor's E-mail Address: _____

Electrical Contractor: _____ Phone: _____

Distributor Name: _____ Phone: _____

WARRANTY STATEMENT

Johnson Controls/UPG is confident that this equipment will operate to the owner's satisfaction if the proper procedures are followed and checks are made at initial start-up. This confidence is supported by the 30 day dealer protection coverage portion of our standard warranty policy which states that Johnson Controls/UPG will cover parts and labor on new equipment start-up failures that are caused by a defect in factory workmanship or material, for a period of 30 days from installation. Refer to current standard warranty policy and warranty manual found on UPGnet for details.

In the event that communication with Johnson Controls/UPG is required regarding technical and/or warranty concerns, all parties to the discussion should have a copy of the equipment start-up sheet for reference. A copy of the original start-up sheet should be filed with the Technical Services Department.

The packaged unit is available in constant or variable air volume versions with a large variety of custom options and accessories available. Therefore, some variation in the startup procedure will exist depending upon the products capacity, control system, options and accessories installed.

This start-up sheet covers all startup check points common to all package equipment. In addition it covers essential startup check points for a number of common installation options. Depending upon the particular unit being started not all sections of this startup sheet will apply. Complete those sections applicable and use the notes section to record any additional information pertinent to your particular installation.

Warranty claims are to be made through the distributor from whom the equipment was purchased.

EQUIPMENT STARTUP

Use the local LCD or Mobile Access Portal (MAP) Gateway to complete the start-up.

A copy of the completed start-up sheet should be kept on file by the distributor providing the equipment and a copy sent to:

Johnson Controls/UPG
 Technical Services Department
 5005 York Drive
 Norman, OK 73069

SAFETY WARNINGS

The inspections and recording of data outlined in this procedure are required for start-up of Johnson Controls/UPG's packaged products. Industry recognized safety standards and practices must be observed at all times. General industry knowledge and experience are required to assure technician safety. It is the responsibility of the technician to assess all potential dangers and take all steps warranted to perform the work in a safe manner. By addressing those potential dangers, prior to beginning any work, the technician can perform the work in a safe manner with minimal risk of injury.

| |
|---|
|  WARNING |
| Lethal voltages are present during some start-up checks. Extreme caution must be used at all times. |

| |
|--|
|  WARNING |
| Moving parts may be exposed during some startup checks. Extreme caution must be used at all times. |

NOTE: Read and review this entire document before beginning any of the startup procedures.

DESIGN APPLICATION INFORMATION

This information will be available from the specifying engineer who selected the equipment. If the system is a VAV system the CFM will be the airflow when the remote VAV boxes are in the

full open position and the frequency drive is operating at 60 HZ. **Do not proceed with the equipment start-up without the design CFM information.**

Design Supply Air CFM: _____ Design Return Air CFM: _____

Design Outdoor Air CFM At Minimum Position: _____

Total External Static Pressure: _____

Supply Static Pressure: _____

Return Static Pressure: _____

Design Building Static Pressure: _____

Outside Air Dilution: Economizer Position Percentage: _____ CFM: _____

Supply Gas Pressure After Regulator W/o Heat Active _____ Inches _____

ADDITIONAL APPLICATION NOTES FROM SPECIFYING ENGINEER:

1034349-UCL-C-0315

REFERENCE

| General Inspection | Completed | See Notes |
|---|--------------------------|--------------------------|
| Unit inspected for shipping, storage, or rigging damage | <input type="checkbox"/> | <input type="checkbox"/> |
| Unit installed with proper clearances | <input type="checkbox"/> | <input type="checkbox"/> |
| Unit installed within slope limitations | <input type="checkbox"/> | <input type="checkbox"/> |
| Refrigeration system checked for gross leaks (presence of oil) | <input type="checkbox"/> | <input type="checkbox"/> |
| Terminal screws and wiring connections checked for tightness | <input type="checkbox"/> | <input type="checkbox"/> |
| Filters installed correctly and clean | <input type="checkbox"/> | <input type="checkbox"/> |
| Economizer hoods installed in operating position | <input type="checkbox"/> | <input type="checkbox"/> |
| Condensate drain trapped properly, refer to Installation Manual | <input type="checkbox"/> | <input type="checkbox"/> |
| Economizer damper linkage tight | <input type="checkbox"/> | <input type="checkbox"/> |
| Gas Heat vent hood installed | <input type="checkbox"/> | <input type="checkbox"/> |
| All field wiring (power and control) complete | <input type="checkbox"/> | <input type="checkbox"/> |

| Air Moving Inspection | Completed | See Notes |
|---|--------------------------|--------------------------|
| Alignment of drive components | <input type="checkbox"/> | <input type="checkbox"/> |
| Belt tension adjusted properly | <input type="checkbox"/> | <input type="checkbox"/> |
| Blower pulleys tight on shaft, bearing set screws tight, wheel tight to shaft | <input type="checkbox"/> | <input type="checkbox"/> |
| Pressure switch or transducer tubing installed properly | <input type="checkbox"/> | <input type="checkbox"/> |

| Exhaust Inspection Powered <input type="checkbox"/> Barometric Relief <input type="checkbox"/> | Completed | See Notes |
|--|--------------------------|--------------------------|
| Check hub for tightness | <input type="checkbox"/> | <input type="checkbox"/> |
| Check fan blade for clearance | <input type="checkbox"/> | <input type="checkbox"/> |
| Check for proper rotation | <input type="checkbox"/> | <input type="checkbox"/> |
| Check for proper mounting (screen faces towards unit) | <input type="checkbox"/> | <input type="checkbox"/> |
| Prove operation by increasing minimum setting on economizer | <input type="checkbox"/> | <input type="checkbox"/> |

| Economizer Inspection Standard <input type="checkbox"/> BAS <input type="checkbox"/> | Completed | See Notes |
|---|--------------------------|--------------------------|
| CO ₂ sensor installed Yes <input type="checkbox"/> No <input type="checkbox"/> | <input type="checkbox"/> | <input type="checkbox"/> |
| Check economizer setting (Reference SSE Control Board LCD menu location) | <input type="checkbox"/> | <input type="checkbox"/> |
| Prove economizer open/close through SSE Board Setting | <input type="checkbox"/> | <input type="checkbox"/> |

| Reheat Mode Normal <input type="checkbox"/> or Alternate <input type="checkbox"/> Not Applicable <input type="checkbox"/> |
|---|
| Humidity Sensor (2SH0401) _____ |

Operating Measurements - Air Flow

| | | | |
|---|----------------------------------|------------------------------------|-------------------------------------|
| Fan operates with proper rotation | ID Fans <input type="checkbox"/> | Exh. Fans <input type="checkbox"/> | Cond. Fans <input type="checkbox"/> |
| Pressure drop across dry evaporator coil (At maximum design CFM) ¹ | | | IWC |
| External Static Pressure | | | IWC |
| Return Static Pressure | | | IWC |
| Supply Static Pressure | | | IWC |
| Supply Air CFM Using Dry Coil Chart | | | CFM |
| Final Adjusted Supply Air CFM ² | | | CFM |

1. Consult the proper airflow to pressure drop table to obtain the actual airflow at the measured pressure differential.
2. Was a motor pulley adjustment or change required to obtain the correct airflow?
Was it necessary to increase or decrease the airflow to meet the design conditions?
If the motor pulley size was changed, measure the outside diameters of the motor and blower pulleys and record those diameters here;

Blower Motor HP _____ FLA _____ RPM _____

Pulley Pitch Diameter _____ Turns Out _____ Final Turns Out _____

Blower Pulley Pitch Diameter _____ Fixed Sheave _____

ELECTRICAL DATA

T1 - T2 _____ Volts T2 - T3 _____ Volts
Control Voltage _____ Volts T1 - T3 _____ Volts

| Device | Nameplate | Measured List All Three Amperages |
|----------------------------------|-----------|--------------------------------------|
| Supply Fan Motor ^{1, 2} | AMPS | AMPS |
| Exhaust Motor (Dampers 100%) | AMPS | AMPS |
| Condenser Fan #1 | AMPS | AMPS |
| Condenser Fan #2 (if equipped) | AMPS | AMPS |
| Condenser Fan #3 (if equipped) | AMPS | AMPS |
| Condenser Fan #4 (if equipped) | AMPS | AMPS |
| Compressor #1 | AMPS | AMPS |
| Compressor #2 (if equipped) | AMPS | AMPS |
| Compressor #3 (if equipped) | AMPS | AMPS |
| Compressor #4 (if equipped) | AMPS | AMPS |

1. VAV units with heat section - simulate heat call to drive VAV boxes and VFD/IGV to maximum design airflow position.
2. VAV units without heat section - VAV boxes must be set to maximum design airflow position.

1034349-UCL-C-0315

OPERATING MEASUREMENTS - COOLING

| Stage | Discharge Pressure | Discharge Temp. | Liquid Line Temp. ¹ | Subcooling ² | Suction Pressure | Suction Temp. | Superheat |
|----------------------|--------------------|-----------------|--------------------------------|-------------------------|------------------|---------------|-----------|
| First | # | ° | ° | ° | # | ° | ° |
| Second (if equipped) | # | ° | ° | ° | # | ° | ° |
| Third (if equipped) | # | ° | ° | ° | # | ° | ° |
| Fourth (if equipped) | # | ° | ° | ° | # | ° | ° |
| Reheat 1st Stage | # | ° | ° | ° | # | ° | ° |

- Liquid temperature should be taken before filter/drier.
- Subtract 10 psi from discharge pressure for estimated liquid line pressure

Outside air temperature _____ °F db _____ °F wb _____ %RH
 Return Air Temperature _____ °F db _____ °F wb _____ %RH
 Mixed Air Temperature _____ °F db _____ °F wb _____ %RH
 Supply Air Temperature _____ °F db _____ °F wb _____ %RH

REFRIGERANT SAFETIES

| Action | Completed | See Notes |
|--|--------------------------|--------------------------|
| Prove Compressor Rotation (3 phase only) by gauge pressure | <input type="checkbox"/> | <input type="checkbox"/> |
| Prove High Pressure Safety, All Systems | <input type="checkbox"/> | <input type="checkbox"/> |
| Prove Low Pressure Safety, All Systems | <input type="checkbox"/> | <input type="checkbox"/> |

OPERATING MEASUREMENTS - GAS HEATING

Fuel Type: Natural Gas LP Gas

| Action | Completed | See Notes |
|-------------------------------------|--|------------------------------|
| Check for gas leaks | <input type="checkbox"/> | <input type="checkbox"/> |
| Prove Ventor Motor Operation | <input type="checkbox"/> | <input type="checkbox"/> |
| Prove Primary Safety Operation | <input type="checkbox"/> | <input type="checkbox"/> |
| Prove Auxiliary Safety Operation | <input type="checkbox"/> | <input type="checkbox"/> |
| Prove Rollout Switch Operation | <input type="checkbox"/> | <input type="checkbox"/> |
| Prove Smoke Detector Operation | <input type="checkbox"/> | <input type="checkbox"/> |
| Manifold Pressure | Stage 1 | IWC <input type="checkbox"/> |
| | Stage 2 (If Equipped) | IWC <input type="checkbox"/> |
| | Stage 3 (If Equipped) | IWC <input type="checkbox"/> |
| Supply gas pressure at full fire | IWC | <input type="checkbox"/> |
| Check temperature rise ¹ | <input type="checkbox"/> measured at full fire | °F <input type="checkbox"/> |

1. Input X Eff. (BTU output)
 1.08 X Temp. Rise

OPERATIONAL MEASUREMENTS - STAGING CONTROLS

| Verify Proper Operation of Heating/Cooling Staging Controls | |
|--|--------------------------|
| Create a cooling demand at the Thermostat, BAS System or Simplicity SE Verify that cooling/economizer stages are energized. | <input type="checkbox"/> |
| Create a heating demand at the Thermostat, BAS System or Simplicity SE Verify that heating stages are energized. | <input type="checkbox"/> |
| Verify Proper Operation of the Variable Frequency Drive (If Required) | |
| Verify that motor speed modulates with duct pressure change. | <input type="checkbox"/> |

FINAL - INSPECTION

| | |
|---|--------------------------|
| Verify that all operational control set points have been set to desired value Scroll through all setpoints and change as may be necessary to suit the occupant requirements. | <input type="checkbox"/> |
| Verify that all option parameters are correct Scroll through all option parameters and ensure that all installed options are enabled in the software and all others are disabled in the software. (Factory software settings should match the installed options) | <input type="checkbox"/> |
| Verify that all access panels have been closed and secured | <input type="checkbox"/> |

OBSERVED PRODUCT DIFFICIENCIES & CONCERNS:
